

Linlar Roof Installation Guide (Mono-Pitch)



1.0 - Introduction

This installation guide has been created to assist in constructing a Liniar conservatory roof from a kit format.

Please note, each roof has been individually designed to meet specific criteria and to suit the shape and dimensions specified. There may be variants in assembly depending on the roof criteria, but the manual should cover all eventualities.

The roof will be provided with a roof layout plan. Ensure that all dimensions and details are correct to the survey supplied before the installation can proceed. Also check that all packages and boxes are present. These will be labelled in accordance to paperwork provided upon delivery.

TO ENSURE THE CORRECT FUNCTIONING OF LINIAR ROOFS, IT IS IMPERATIVE THAT THE INSTRUCTIONS IN THIS GUIDE ARE FOLLOWED, IN THE CORRECT ORDER.

Care of Products

When storing, handling or erecting your Liniar roof, please keep the following in mind :

- When unwrapping, take care not to damage products with a knife.
- Always check the components before installing
- PVCu components should not be left out in freezing conditions.
- Do not leave coloured foiled components in their wrapping in direct heat or sunlight.
- Store polycarbonate roof panels in a dry safe area.
- Take care when fitting caps/trims with any type of force

Sealing

It is imperative that the correct sealant is used when sealing the roof. The diagrams below show the sealants required dependant on glazing material.



- Self cleaning glass

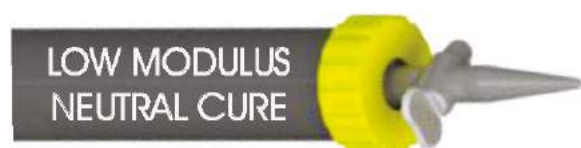

- Polycarbonate glazing
- Standard sealed units

For a perfect colour match, use the Liniar approved range. See www.liniar.co.uk/supplies for details.

Further Assistance

Your roof kit should include all the information you need – but if you do need to get in touch with any queries, please use the contact details on the back cover.

Videos

To watch videos about the Liniar roof, please visit www.liniar.co.uk/videos and filter by 'Conservatories'.

Tools & Consumables Required



Angle Grinder
Chasing out masonry for flashing



Cordless Drill
With Pozi bits and suitable drills for pilot holes in PVCu and aluminium.



SDS / Hammer Drill
With appropriately sized masonry bits for proprietary fixings.



Hand Saw
Notching frames



Utility Knife
General use



Clamps
Secure eaves beams in place when drilling and fixing



Glazing Hammer
Fitting trims and caps



Angle Finder
General measuring and checking of angles/pitches



Spirit Level
General level checking



Tape Measure
General measuring and checking



10mm and 17mm Spanners
Securing jack rafters (10mm) and fitting internal radius covers (17mm)



10mm Socket Wrench
Secure all roof bars



60mm diameter drill bit / hole saw
Multi-Positional outlet in guttering



2.5mm Allen Key
Tighten the grub screws in the D-Ring connectors



Low modulus neutral cure sealant
With silicone gun



Suitable uPVC Adhesive
Securing trims and mouldings in place

2.00 – Lean To Roof Assembly Overview



Installation Steps...



Preparation
Section 3.00,
pages 6-7



**Scribing Half Ridge /
Wallplate position**
Section 3.01,
pages 8-9



Eaves Beam Assembly
Section 3.02,
pages 10-11



Raked Frame Notching
Section 3.03,
pages 12-13



Raked Frame Assembly
Section 3.04,
pages 14-15



Glazing Retainer Assembly
Section 3.05,
pages 16-17



Wallplate / Half Ridge Assembly
Section 3.06, pages 18-19
Section 3.07, pages 20-21



Wall / End Bar Assembly
Section 3.08,
pages 22-23



Transom Bar Assembly
Section 3.09,
pages 24-25



Wallplate / Half Ridge Cover Assembly
Section 3.10, pages 26-27
Section 3.11, pages 28-29



Wallplate / Half Ridge / Wall Bar flashing
Section 3.12,
pages 30-31



Glazing Assembly
Section 3.13,
pages 32-33



Roof Bar Top cap Assembly
Section 3.14,
pages 34-35



Roof Bar End cap Assembly
Section 3.15,
pages 36-37

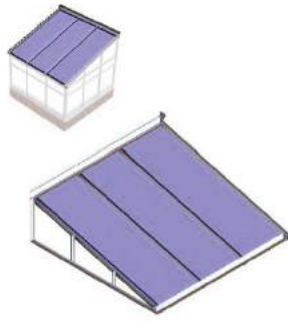

Internal Eaves/Ridge Trims Assembly
Section 3.16,
pages 38-39

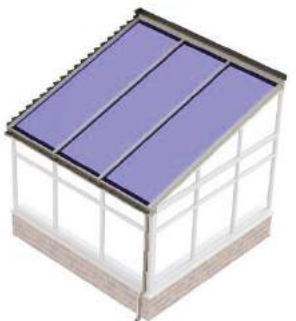

Guttering Assembly
Section 6.00,
pages 58-59

3.00 – Preparation

Before the roof is installed, ensure the framework below is fully assessed and all roof components are available. All relevant sizes are shown on the roof kit paperwork.

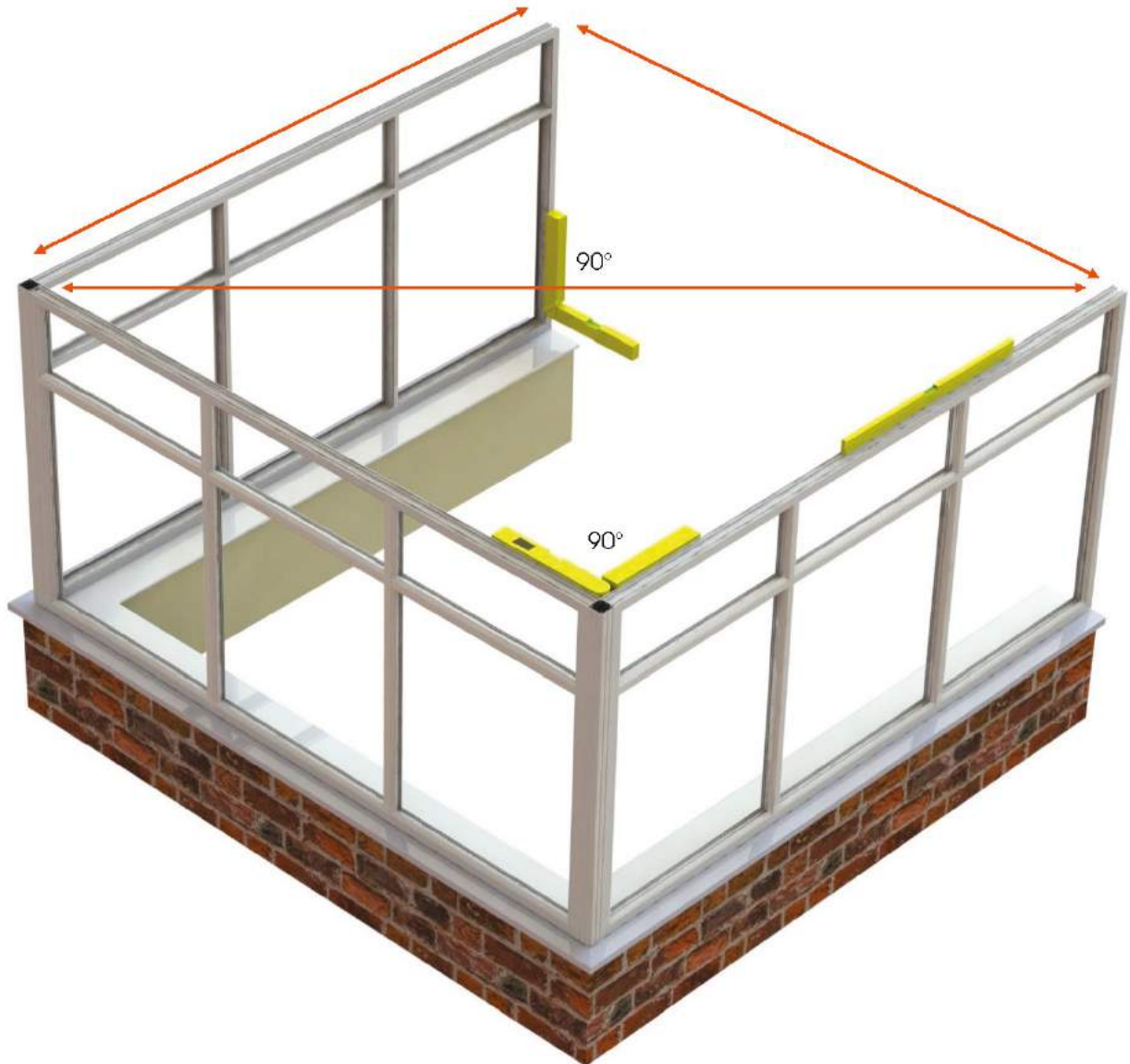

Related Components ...

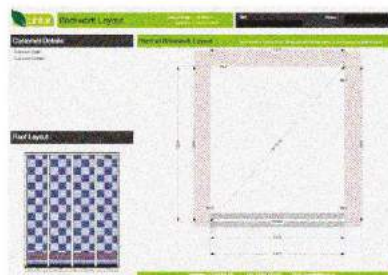

Brickwork
layout
paper work

Measure Length, Width and Diagonals of Frame

Measure the roof area you will be working on and check that all the frames have been installed square and are the correct size. The internal frame dimensions will be provided within the paperwork shown below.

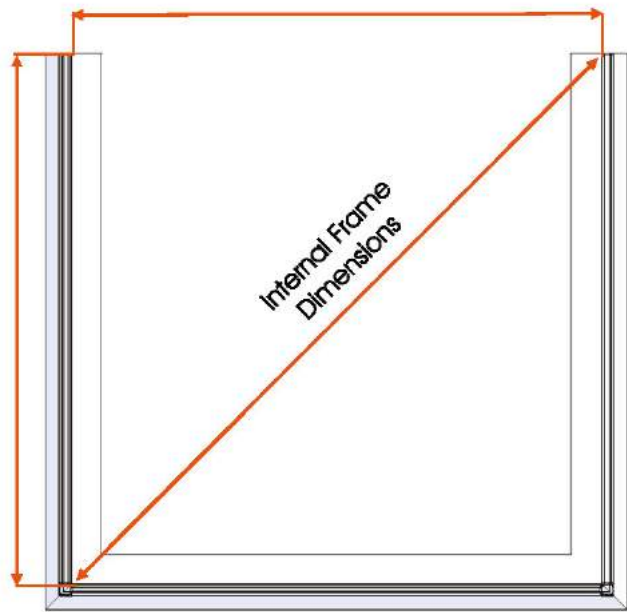
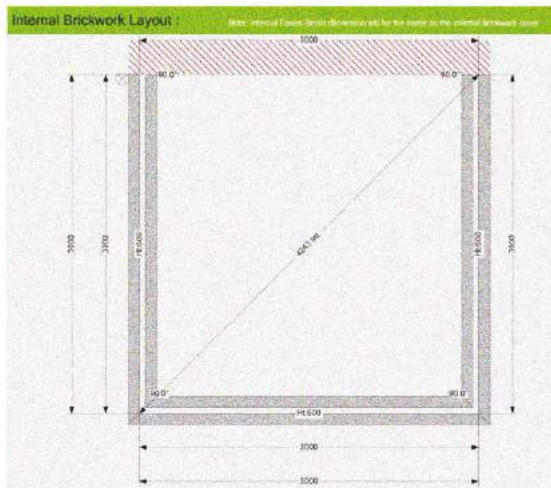

Check level

Use a spirit level and level up if necessary before the eaves beams are fitted.



Check Bill of Materials

Use the paperwork that came with your roof kit to make sure you have received all the components that are listed before you start.

Remove Dummy Sashes and Glazing

Remove dummy sashes and any glazing from frames to allow ease of eaves installation. This is because the eaves is fixed from the underneath so dummy sashes/glazing prevent access.



** The installer must ensure suitable lateral and vertical support is provided. Liniar accepts no responsibility for the overall structural stability of the conservatory or for the failures of its fixings, members or existing structures **

3.01 – Scribing Half Ridge / Wallplate Position

Before the roof is installed, the datum position for the wallplate / half ridge should be scribed on the wall to aid in positioning and securing the wallplate / half ridge.

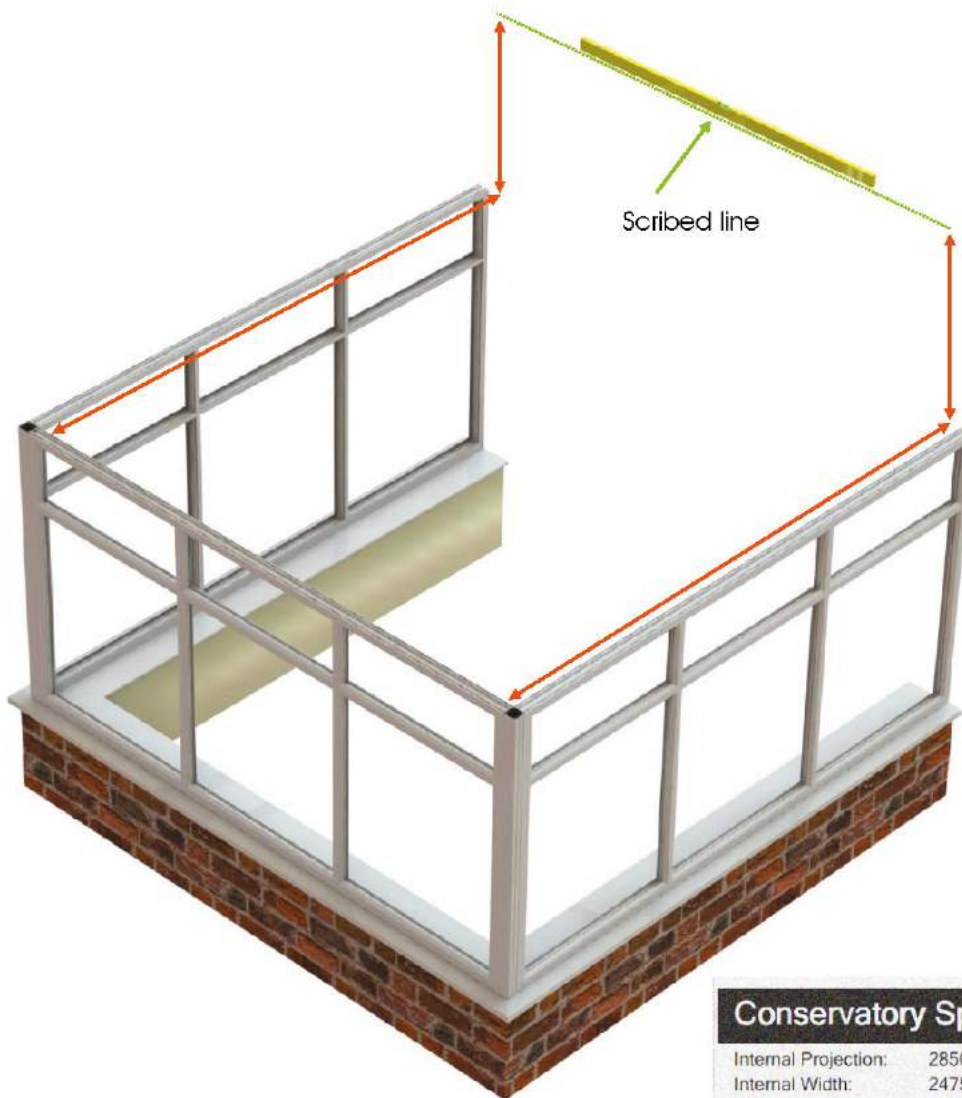

Conservatory Spec:

Internal Projection:	2850mm
Internal Width:	2475mm
Int. Floor Area:	7m ²
Roof Pitch:	15.0°
Roof Weight (approx):	182.261Kg
Frame Depth:	70mm
Frame Height:	2090mm
Roof Height:	994 mm (above Alu) : 855 mm (below Alu)
O/A Height (approx):	3084mm
Glazing Area (approx):	7.118m ²
Roof (Profile) Colour:	Cream On Cream
Glazing Type:	Unglazed
Roof Vent:	N/A

Related Components ...



Roof layout drawing

Scribing of Wallplate Assembly

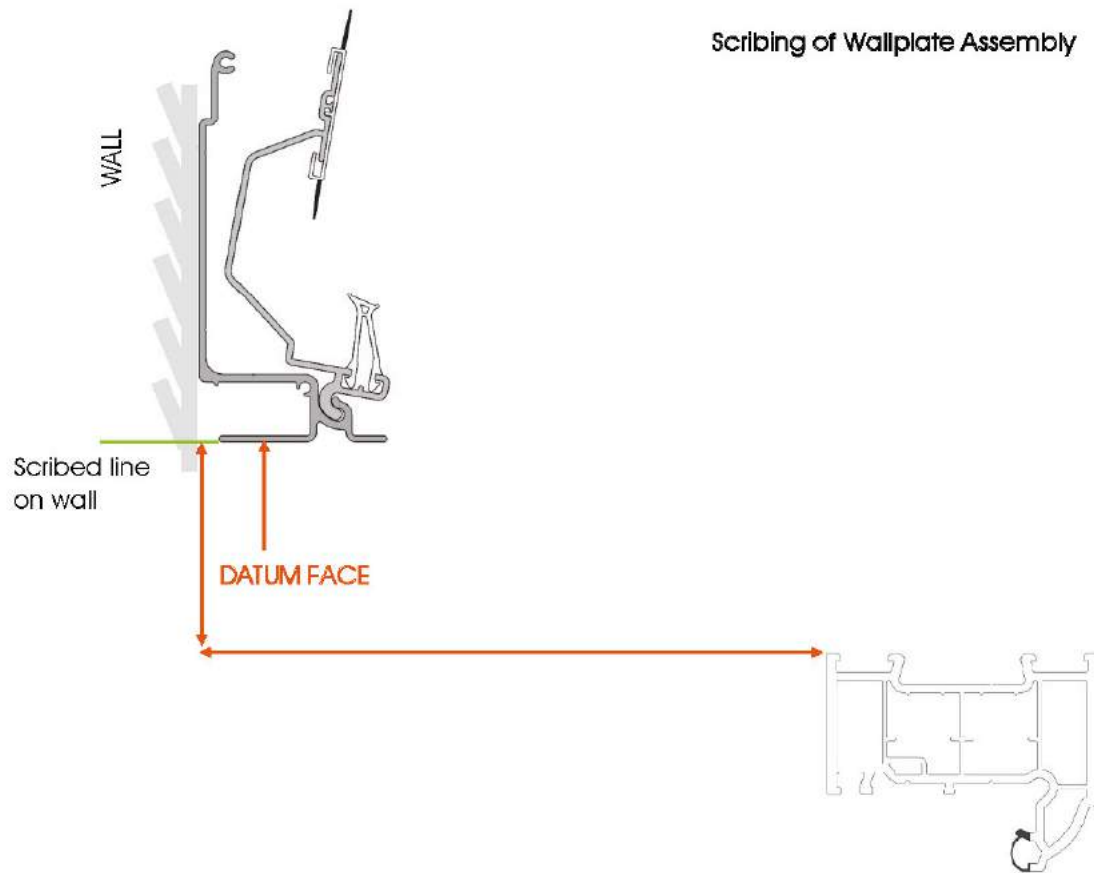

Scribing of Half Ridge Assembly

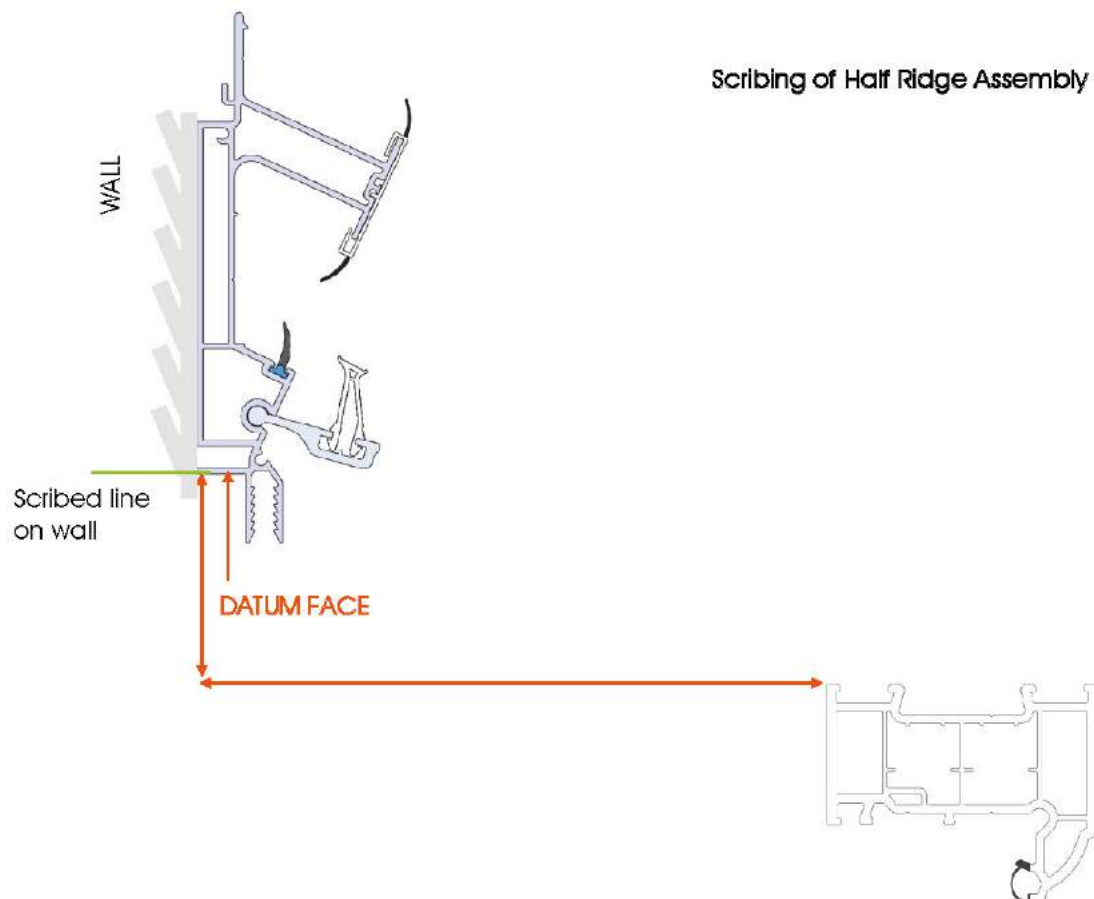

3.02 – Eaves Beam Assembly

This section shows the correct procedure for installing the eaves beams.

Ensure all fixings are located in the eaves pivot prior to fixing to the frame. They cannot be inserted once the eaves beam is in the final position.

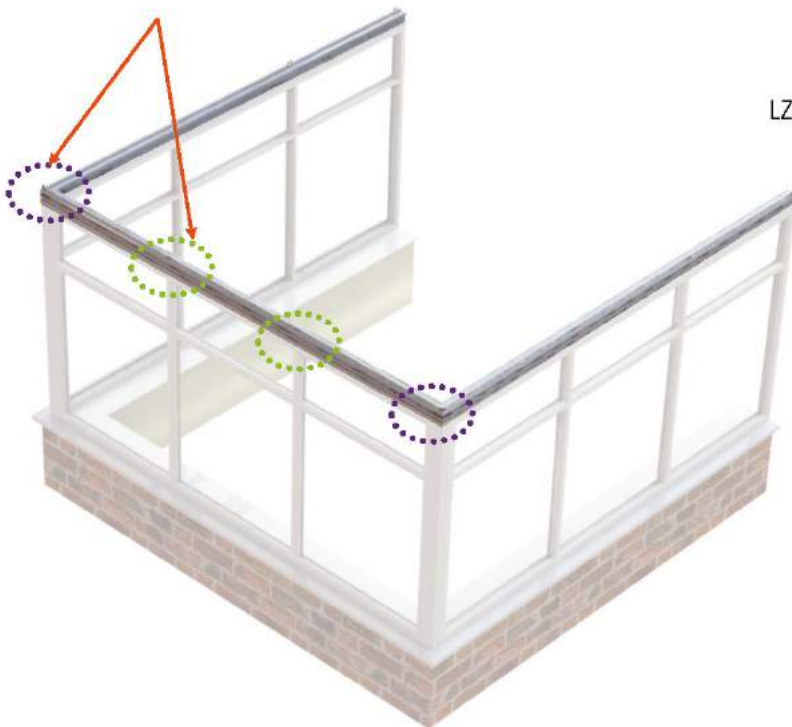

LZFX0020

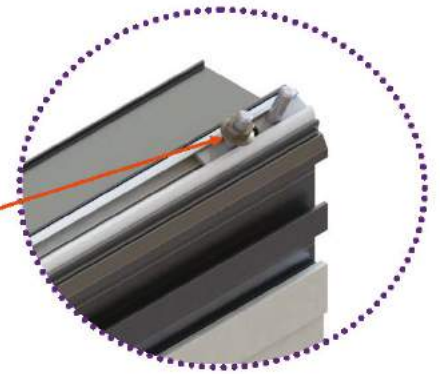

Lean-To (with side eaves)

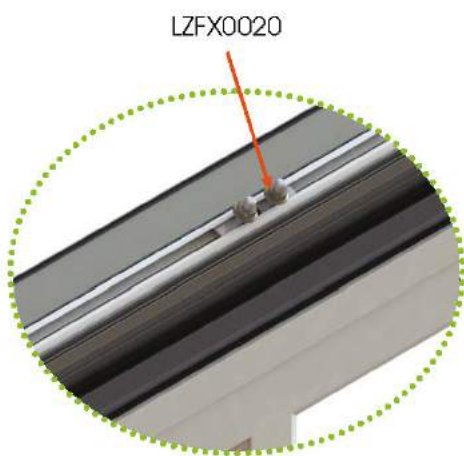

LZFX0020

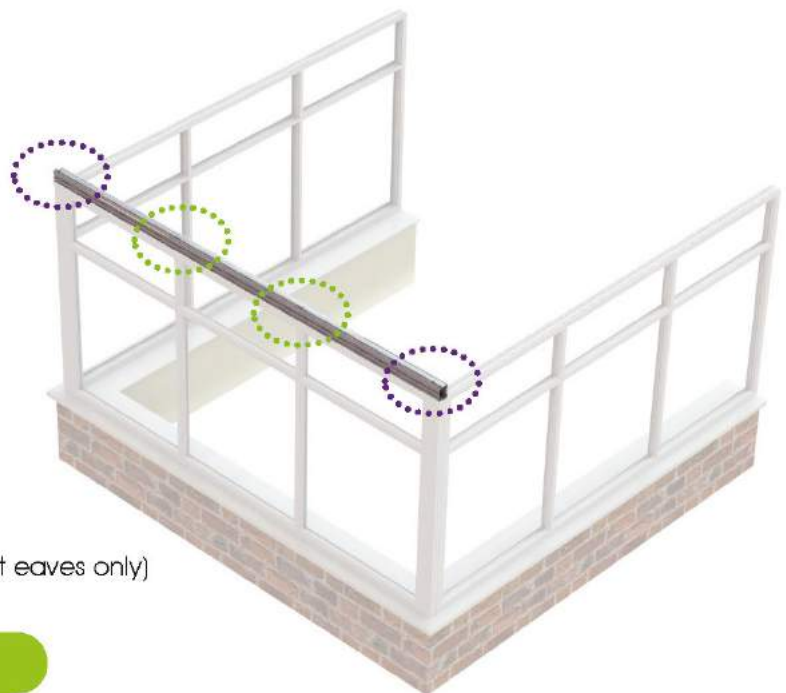

Lean-To (front eaves only)

Related Components ...

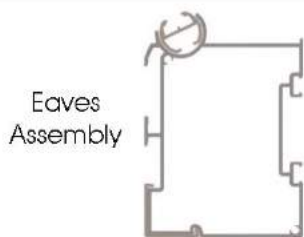

Eaves Assembly



LZFX0018



LZFX0020

Vertical Cleats



LZFX0004

Required if side eaves beams are to be installed



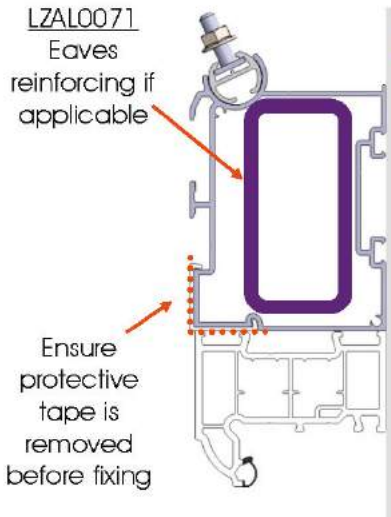

Align with inside face of frames

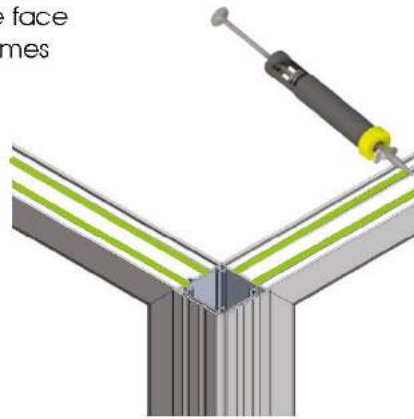

No cleats required when there are no side eaves present

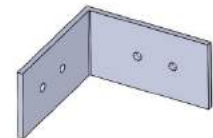

LZSU 8261
90°

Lean-To with one side eaves

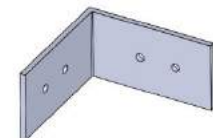

LZSU 8261
90°

Lean-To with both side eaves

** Check correct number of fixings in Eaves Beams prior to fixing in position **

A continuous bead of appropriate sealant should be applied to the two inner legs on top of frames before positioning the eaves beams to create a weathertight seal.

The eaves beams can then be positioned as instructed in the paperwork for the roof kit. Connect the eaves beams with the cleats provided as shown below. The roof kit will include the correct cleats. The angle of these will be determined by whether the roof is an Edwardian, 3 Facet Victorian or 5 Facet Victorian.

Once the eaves beams are positioned on the frames (aligning the inside edges) they can be fixed to the frames with appropriate fixings at no greater than 600mm intervals, leaving 150mm from corners of frames, as shown below.

Installing Cleats

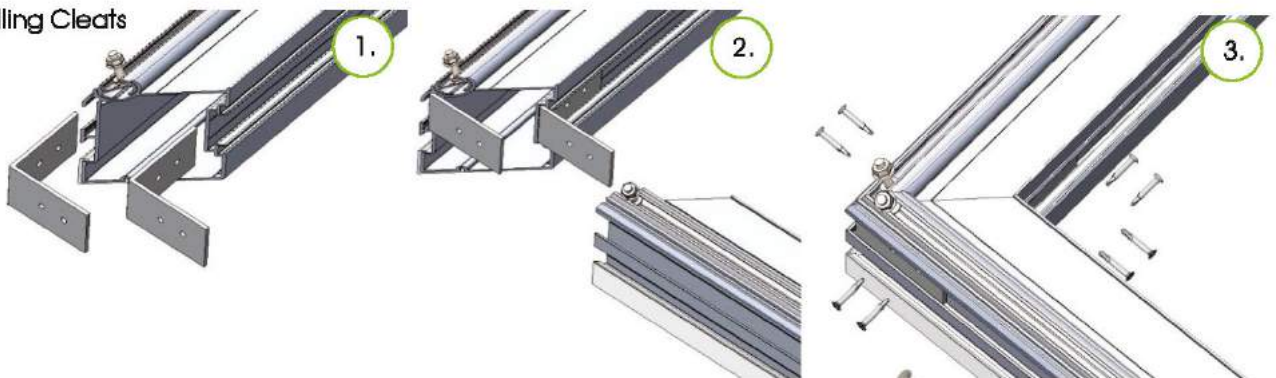

** Ensure a continuous bead of silicone is applied to the outside edge of the frames and eaves beams where they meet the wall **

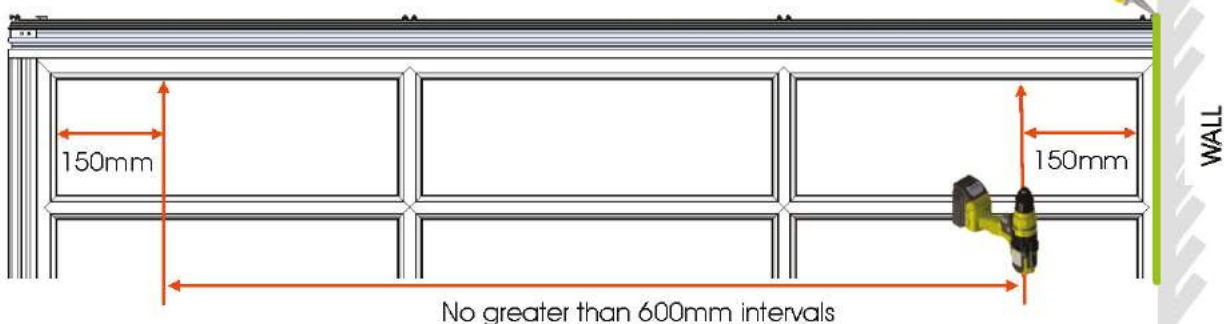

3.03 – Raked Frame Notching

In order for the half ridge / wallplate assembly to sit in the correct position, the raked frames that go at the ends of the roof will need to have notches cut out of them. This section details the sizes of notch depending on whether your roof uses the Linear Wallplate or Half Ridge. The pitch of the roof can also affect the notching detail.

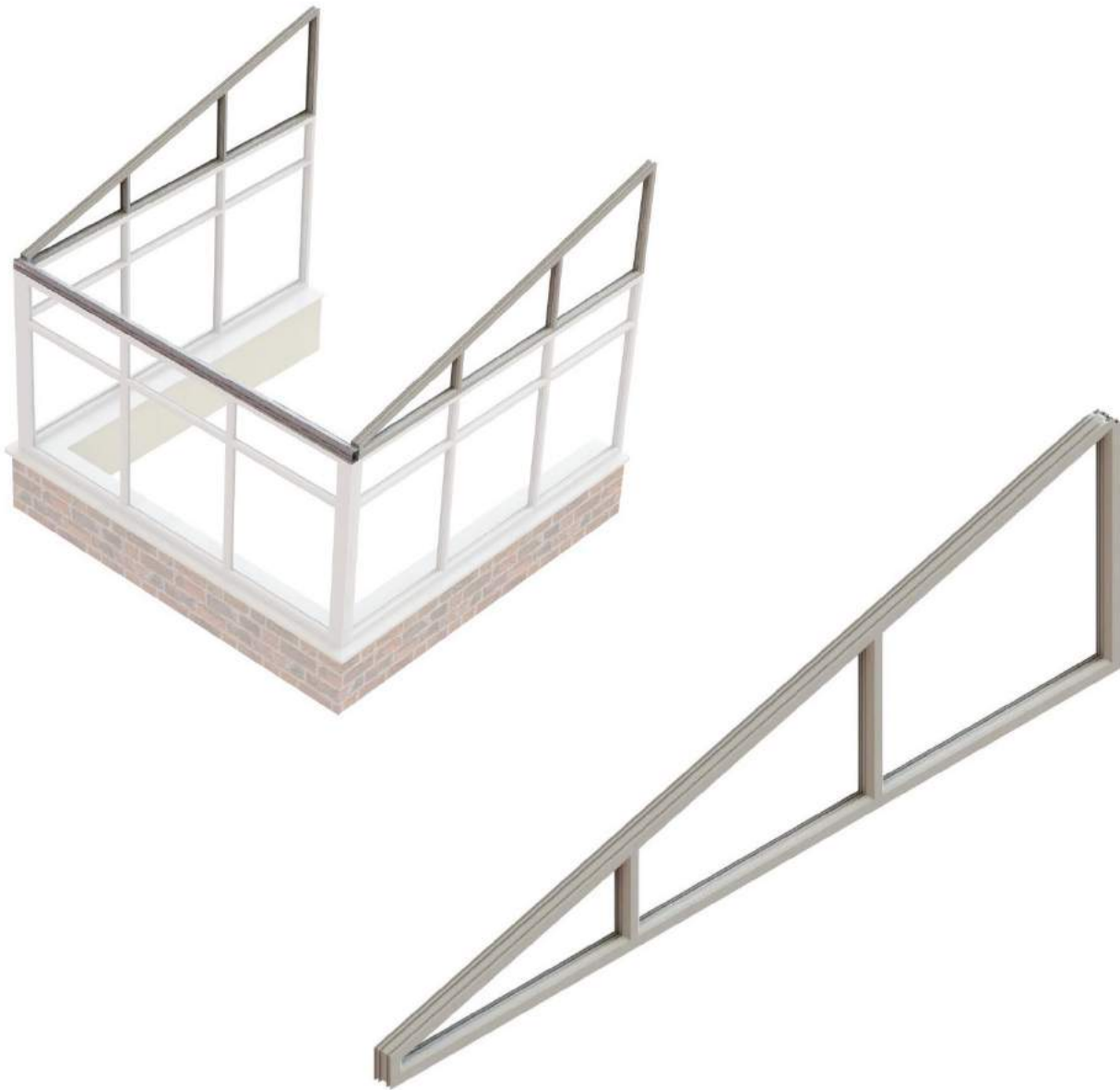

Related Components ...



Roof layout drawing

Wallplate - 5° to 14°

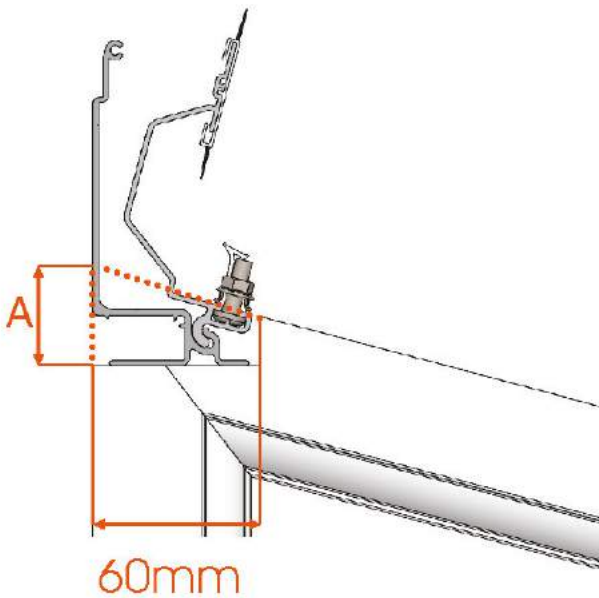

Pitch °	Dim. A (Notch Depth)
5	26.0
6	26.8
7	27.6
8	28.3
9	29.1
10	29.9
11	30.7
12	31.5
13	32.3
14	33.1

Half Ridge - 15° to 40°

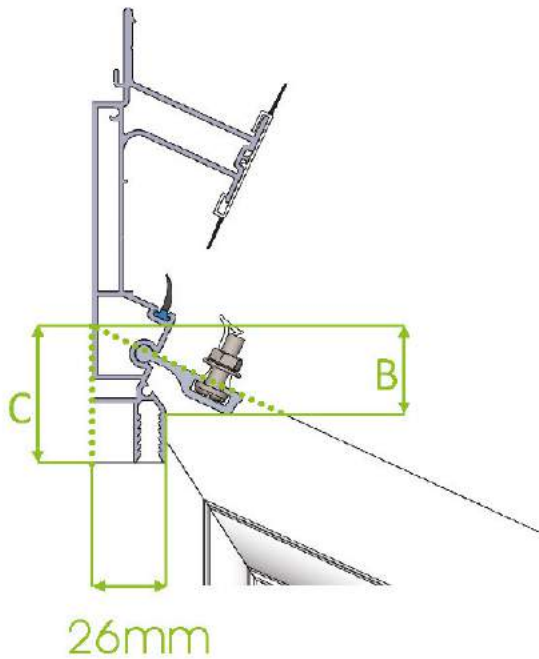

Pitch °	Dim. B (top flat depth)	Dim. C (Notch Depth)
21	27.4	46.6
22	28.3	47.0
23	29.2	47.4
24	30.1	47.8
25	31.0	48.1
26	31.9	48.6
27	32.8	48.9
28	33.7	49.4
29	34.7	49.8
30	35.6	50.2
31	36.5	50.6
32	37.4	51.1
33	38.3	51.5
34	39.2	52.0
35	40.1	52.5
36	41.1	53.0
37	42.0	53.5
38	43.0	54.0
39	43.9	54.5
40	44.9	55.1

Pitch °	Dim. B (top flat depth)	Dim. C (Notch Depth)
15	22.1	44.5
16	23.0	44.8
17	23.9	45.2
18	24.8	45.5
19	25.7	45.9
20	26.6	46.3

3.04 – Raked Frame Assembly

Installing raked frames



Lean-To (with side eaves)

Lean-To (front eaves only)



Related Components ...



LZPE0024



Bespoke infill wedges



Raked frames are not provided as part of roof kit

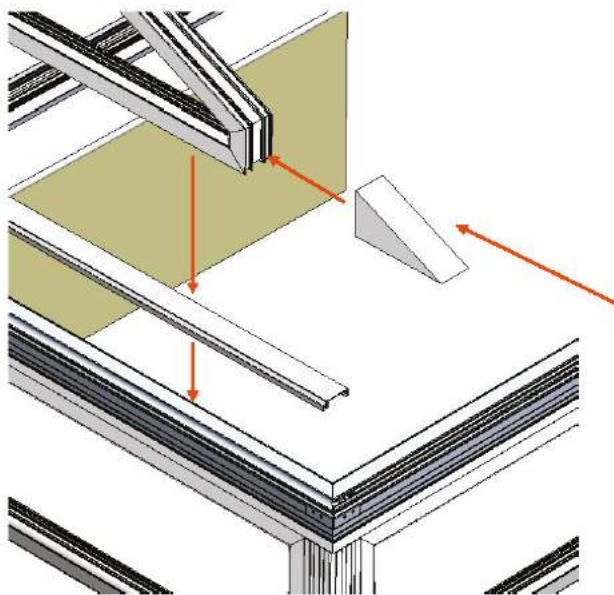

Secure in place using a suitable adhesive

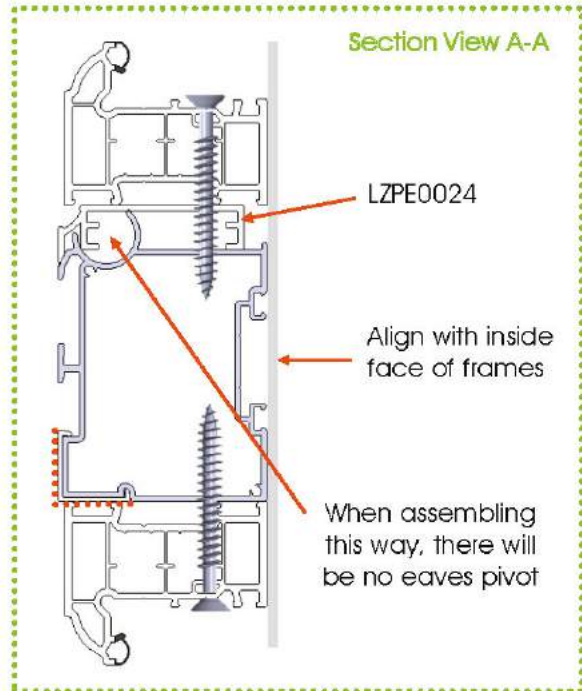

Use LZPE0024 as a spacer to position the raked frame on top of the eaves beam. Secure in place, aligning the inside face of frames.

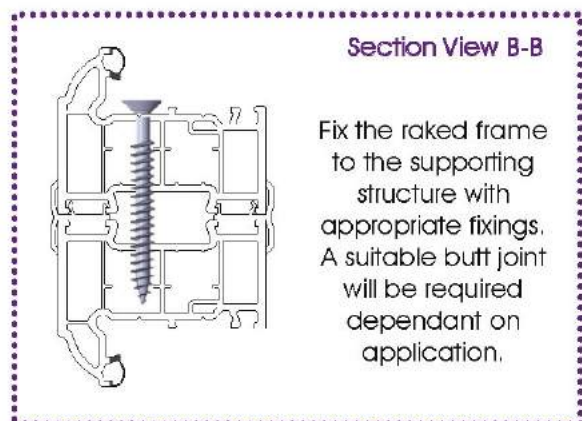
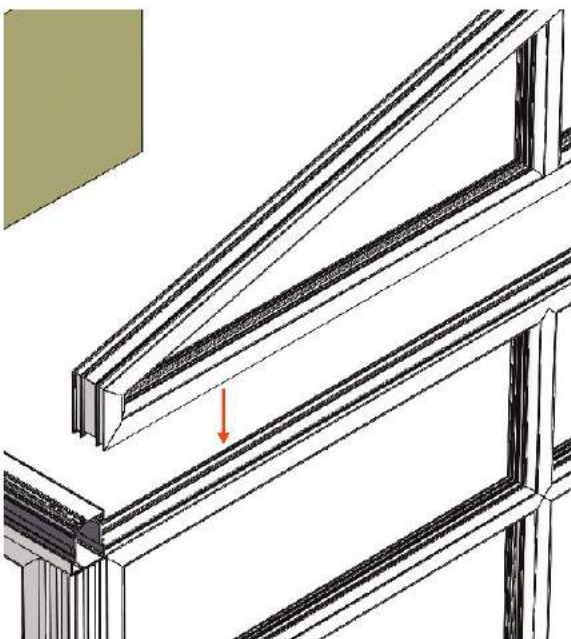



Position the left and right eaves beams, aligning the inside face with the frames. Secure in place with appropriate frame fixings (600mm centres, 150mm from corners).

3.05 – Glazing Retainer Assembly

Ensure the glazing retainers are installed prior to fitting the bars

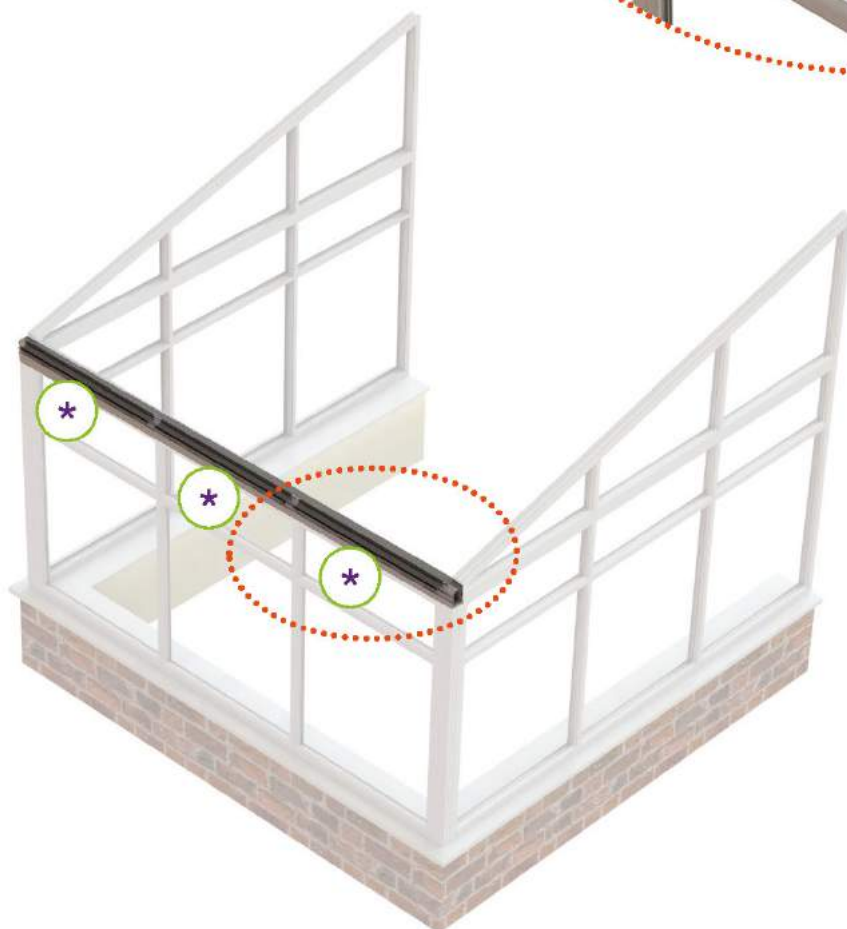
Glazing retainers sit at the bottom of all glazed units



 Indicates position of glazing retainers

Related Components ...



Glazing Retainer Assembly



LZSU0087



Ensure gasket is fitted in the correct orientation on all glazing retainers

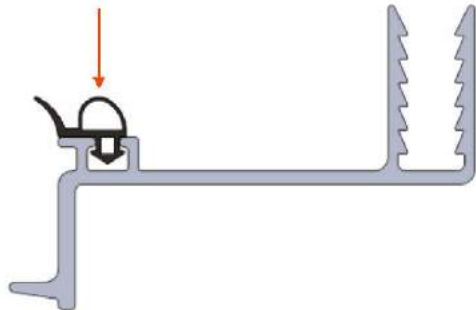

1. Insert glazing retainer into eaves pivot in this orientation

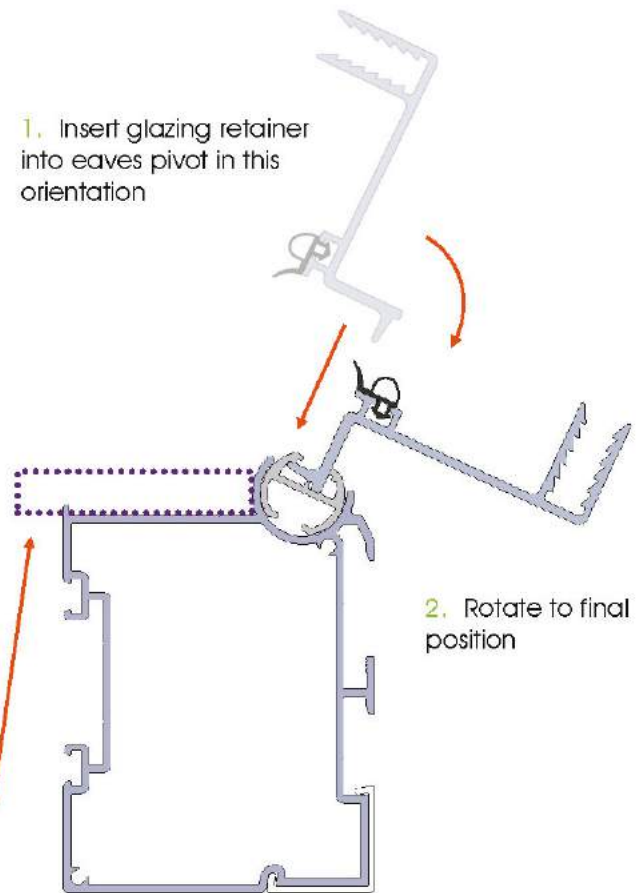

2. Rotate to final position



The eaves beam cloaking foam will overhang the eaves by 15mm. This will eventually be cloaked by the internal eaves cover.

Eaves beam cloaking foam (LZSU0087)

The eaves beam cloaking foam adds extra insulation, minimises condensation on glass and improves the overall aesthetics of the eaves beams.

The foam will be supplied in rolls and requires cutting to length to fit the eaves beams.

Look for adhesive backed foam 6mm x 60mm. Remove backing tape and apply to the full length of the eaves beam.

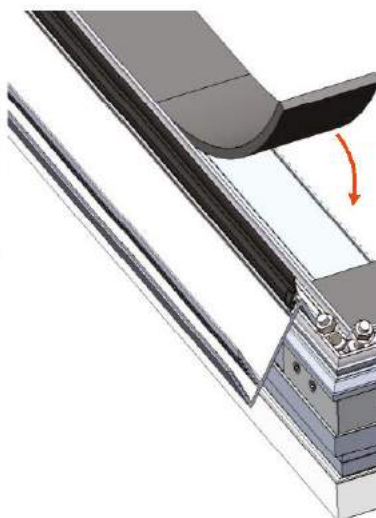

3.06 – Wallplate Assembly – Roof Pitches 5° to 14°

This section shows the installation of the wallplate which is used on roofs with pitches between 5° and 14°.

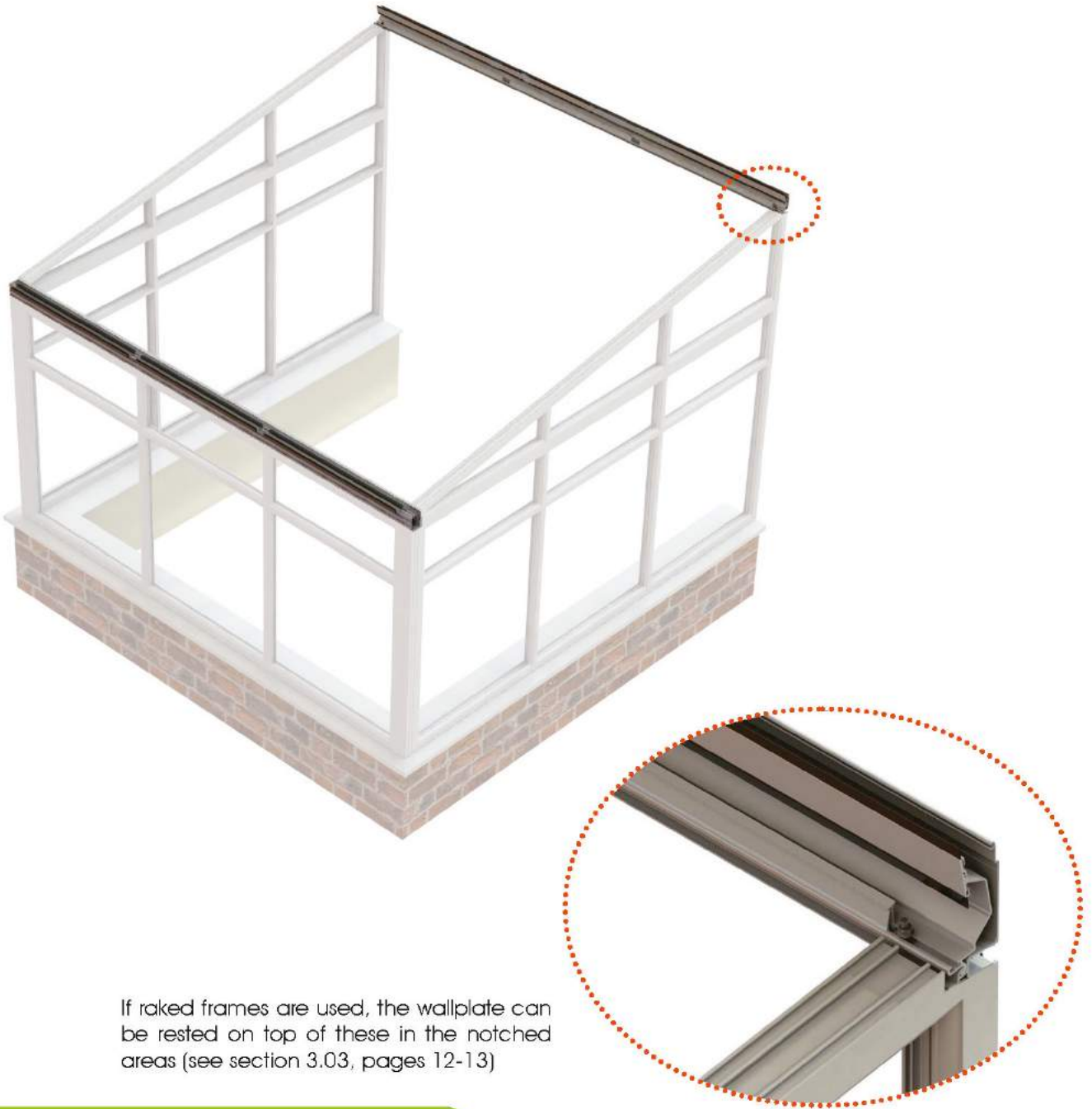

Related Components ...



Wallplate Assembly



LZPE0012



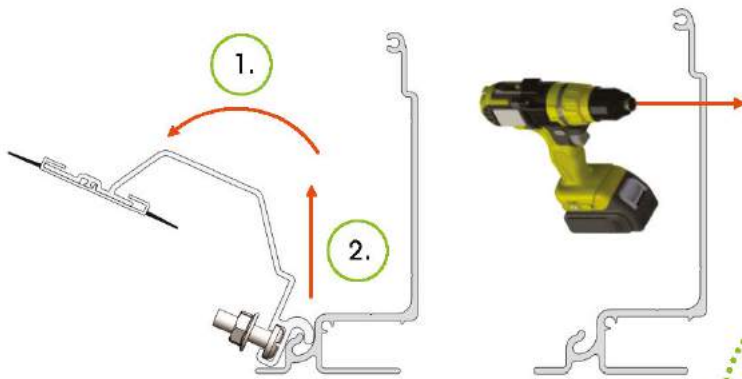

Remove the wallplate wing by tilting forward and then lifting.

Glazing supports to be inserted between fixings in the wallplate wing. This will help to position the fixings and the roof bars.



Drill a series of pilot holes in the wallplate to fix to the wall using the groove indicated as a guide. The holes should be appropriately sized for the proprietary fixings to be used. Holes should be evenly spaced along the length of the wallplate at approximately 600mm centres.

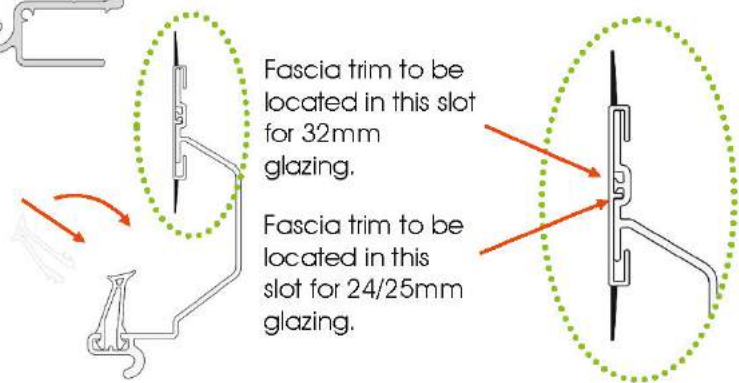

Fascia trim to be located in this slot for 32mm glazing.

Fascia trim to be located in this slot for 24/25mm glazing.

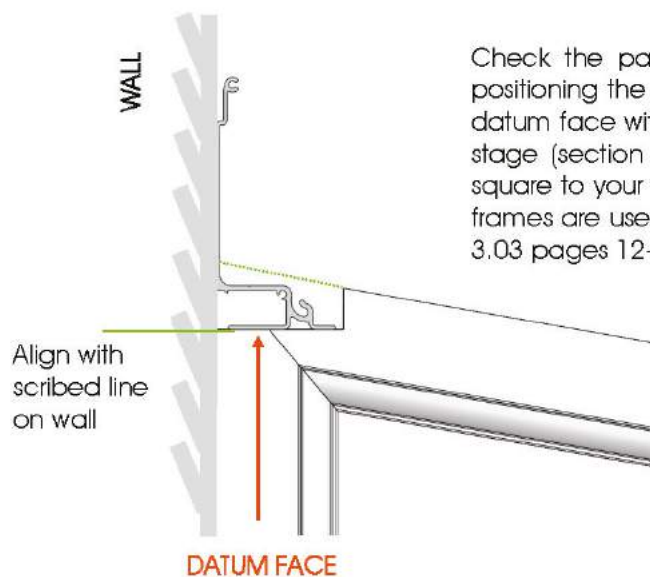

Align with scribed line on wall

DATUM FACE

Check the paperwork supplied with the roof kit for the dimension for positioning the wallplate. Position wallplate against the wall and align the datum face with the scribed line on the wall drawn during the preparation stage (section 3.01, pages 8-9). Check that the wallplate is level and square to your frames. **SUPPORT THE WALLPLATE** during this stage. If raked frames are used, the wallplate can be rested on top of these (see section 3.03 pages 12-13).

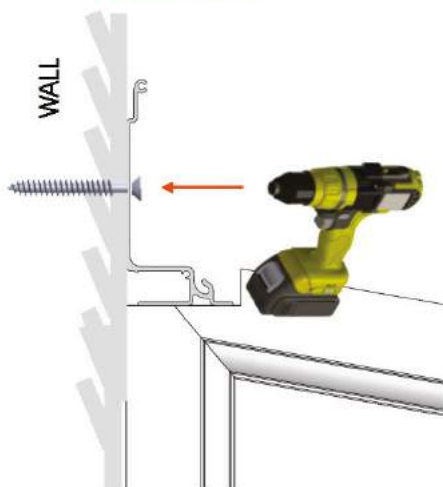
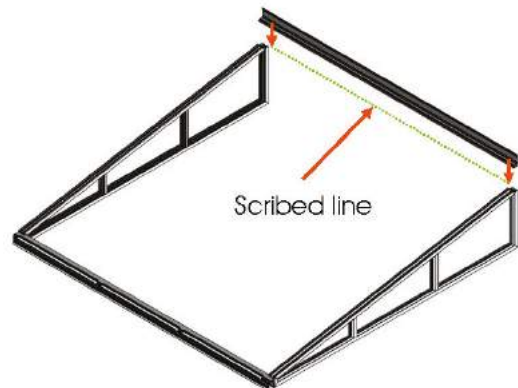

Once the wallplate is in position and level, secure into position with proprietary fixings.

**Clean all dust from wallplate before refitting wallplate wing **

Fit the wallplate wing back into the wallplate by reversing the removal process. Once secured to the wall, check with a spirit level and adjust where necessary.

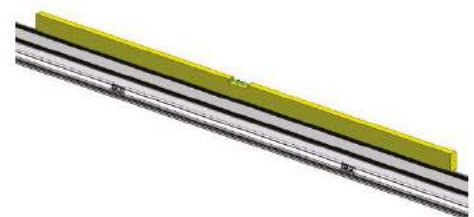
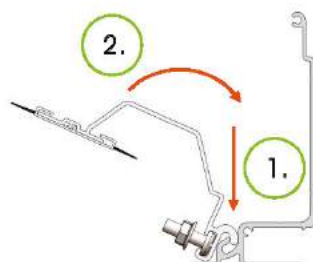

3.07 – Half Ridge Assembly – Roof Pitches 15° to 40°

This section shows the installation of the half ridge which is used on roofs with pitches from 15° to 40°.



If raked frames are used the half ridge can be rested on top of these in the notched areas (see section 3.03, pages 12-13)

Related Components ...



Half Ridge Assembly



LZPE0012



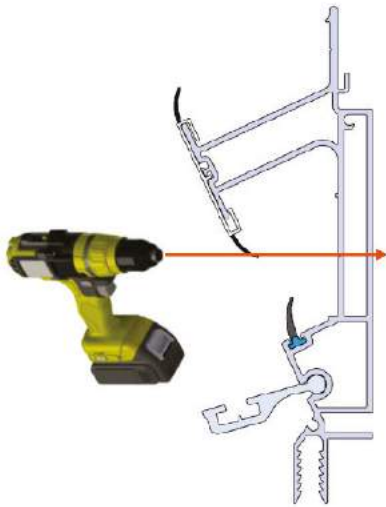

Drill a series of pilot holes in the half ridge to fix to the wall using the groove indicated as a guide. The holes should be appropriately sized for the proprietary fixings to be used. Holes should be evenly spaced along the length of the half ridge at approximately 600mm centres.

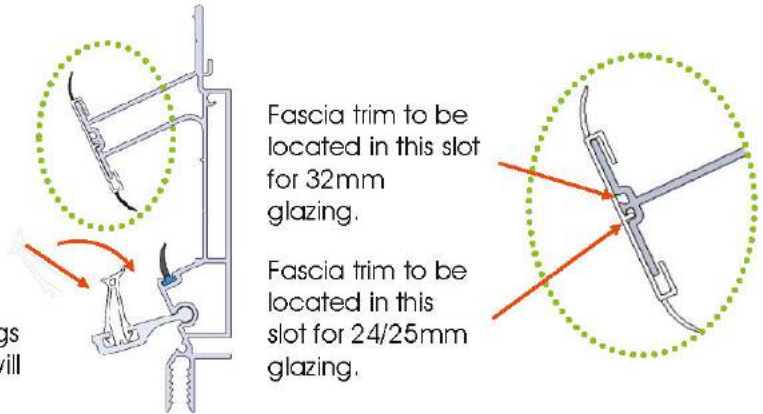

Fascia trim to be located in this slot for 32mm glazing.

Fascia trim to be located in this slot for 24/25mm glazing.

Glazing supports to be inserted between fixings on half ridge before fitting to the wall. This will help to position the fixings and the roof bars.

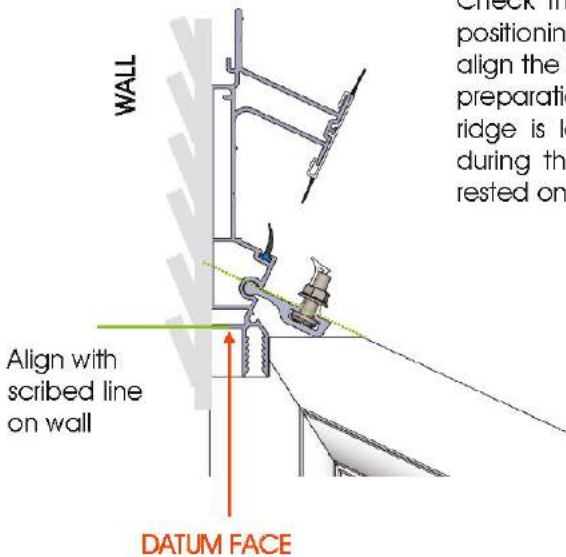

Check the paperwork supplied with the roof kit for the dimension for positioning the half ridge. Position the half ridge against the wall and align the datum face with the scribed line on the wall drawn during the preparation stage (see section 3.01, pages 8-9). Check that the half ridge is level and square to your frames. **SUPPORT THE HALF RIDGE** during this stage. If raked frames are used, the half ridge can be rested on top of these (see section 3.03 pages 12-13).

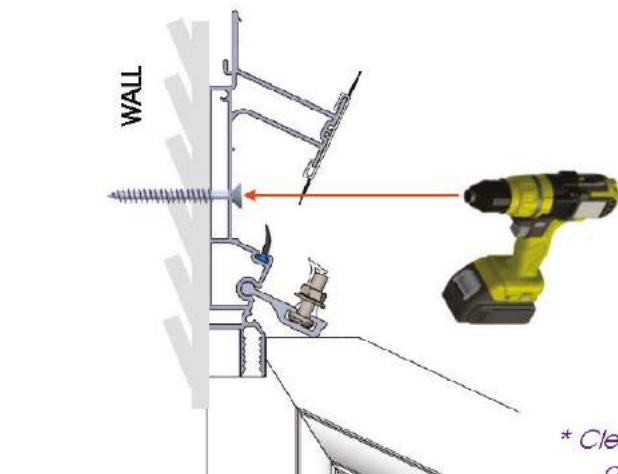
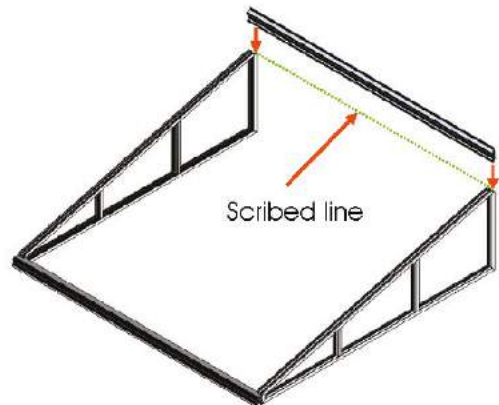

Once the half ridge is in position and level, secure into position with proprietary fixings.

Once secured to the wall check with a spirit level and adjust where necessary.



** Clean all dust from half ridge once secured to wall **

3.08 – Wall / End Bar Assembly

End bars are secured to the half ridge / wallplate and the eaves beam. They are then secured to the raked frames on which they are positioned. Wall bars that do not sit directly on top of a frame should be fixed to the wall.

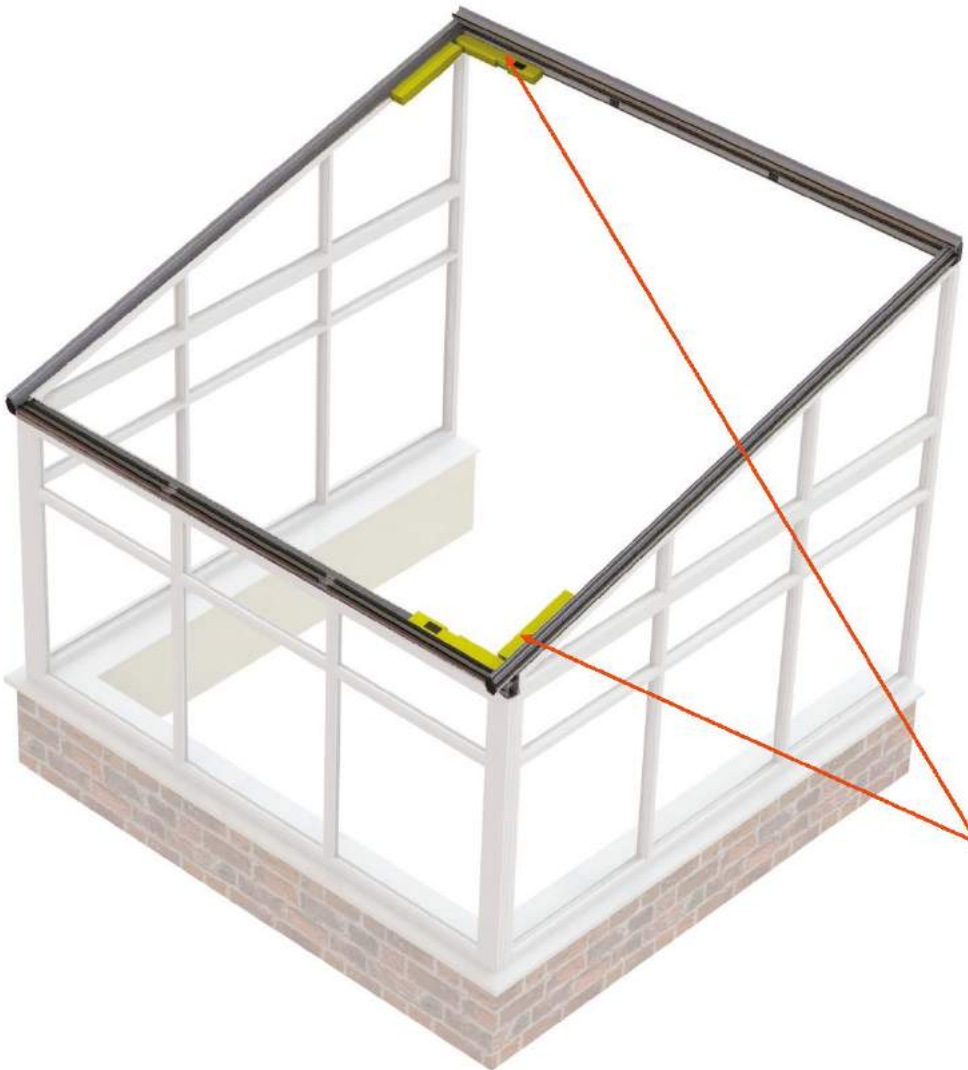

Check bars are square and check dimensions to paperwork before securing in place.



Related Components ...



Wall Bar Assembly



LZFX0020



LZFX0018





Ensure the end cap mounting bracket is in the correct orientation (see images above) and installed to the bars prior to fitting.

The wall / end bar is fixed in place with 1 x M6 flange nut at the eaves beam and one at the half ridge / wallplate.

Once fixed in place use an angle finder to check the wall / end bars are set at the correct angle.

End Bars

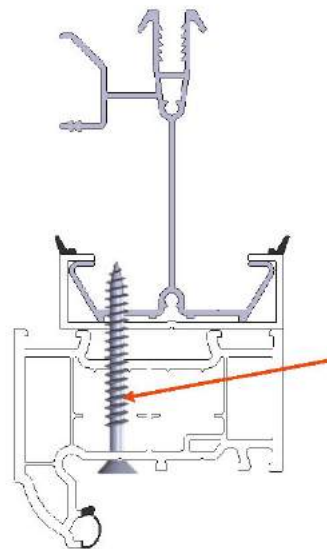
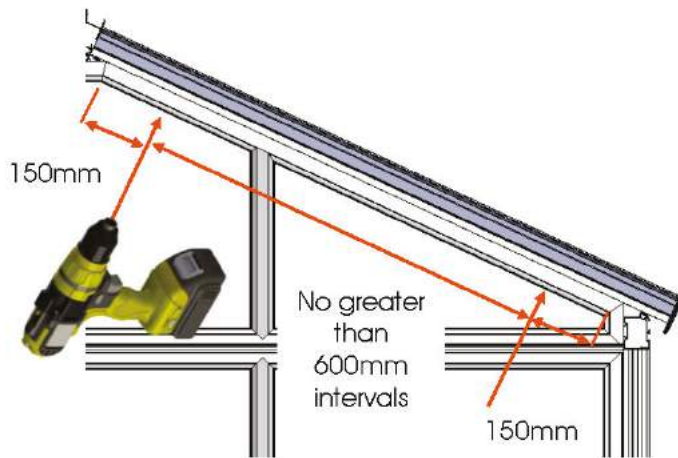

End bars should be aligned with the internal face of the raked frame. The end bars can then be fixed to the raked frame. Where possible, fix through the frame into the aluminium of the end bar. If this is not possible, fix through the end bar into the frame.

Wall Bars

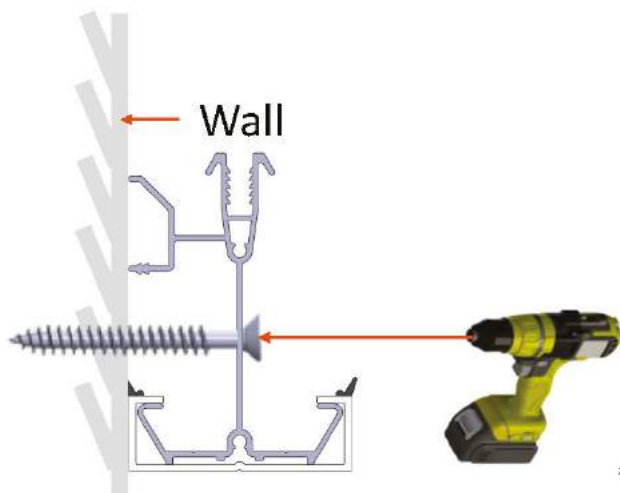

Before fixing to the wall, ensure all bars are in the correct position and square.

Clearance holes will need to be drilled in the wall bars to fix in position. Appropriate fixings should be used to fix wall bars securely. Fix with approximately 600mm centres.

** Clean all dust from wall bars once secured to wall **

3.09 – Transom Bar Assembly

The transom bars can now be installed.

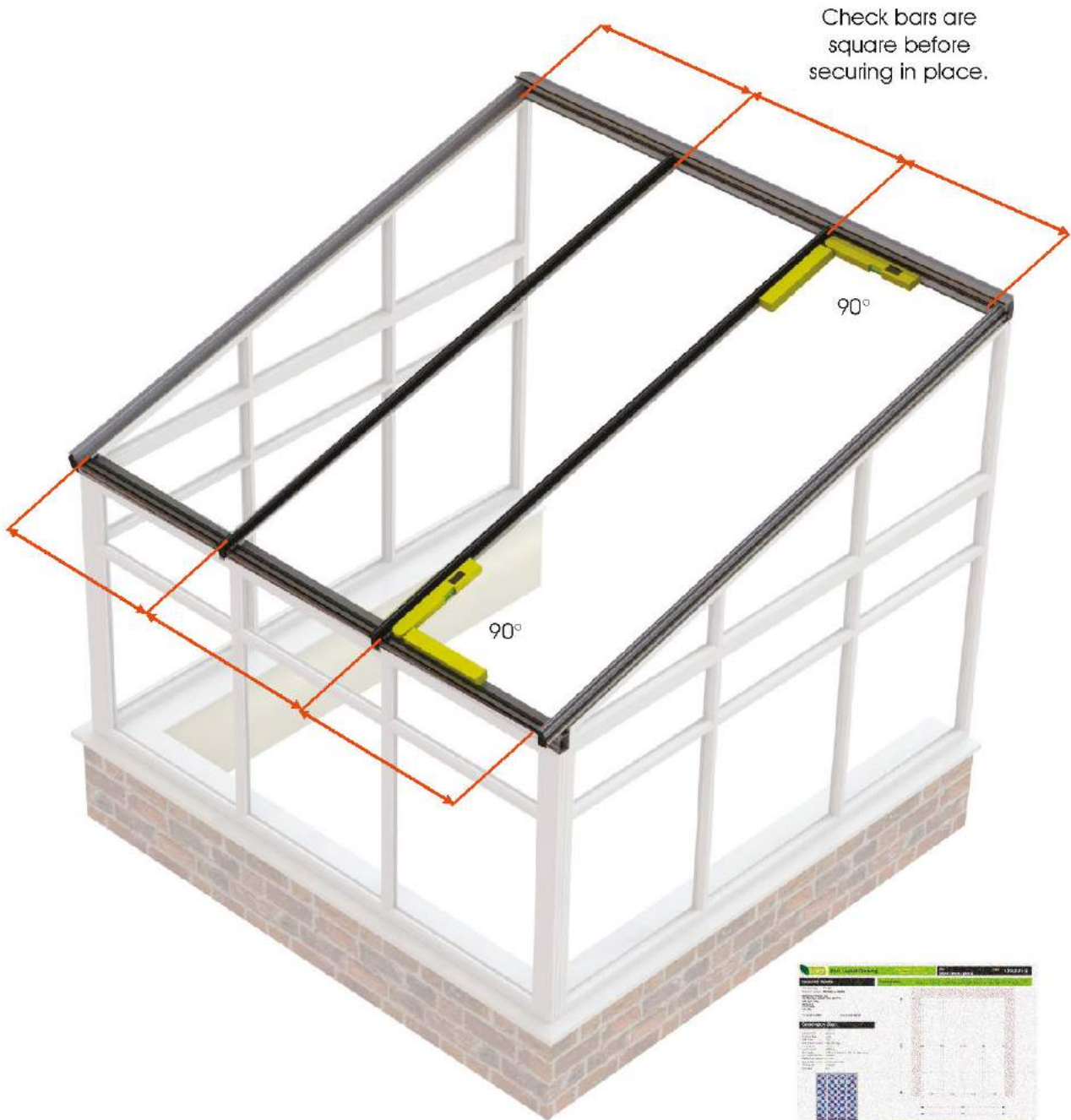

Also check dimensions from the paperwork for the positioning of the bars

Related Components ...



Transom Assembly



LZFX0020



LZFX0018



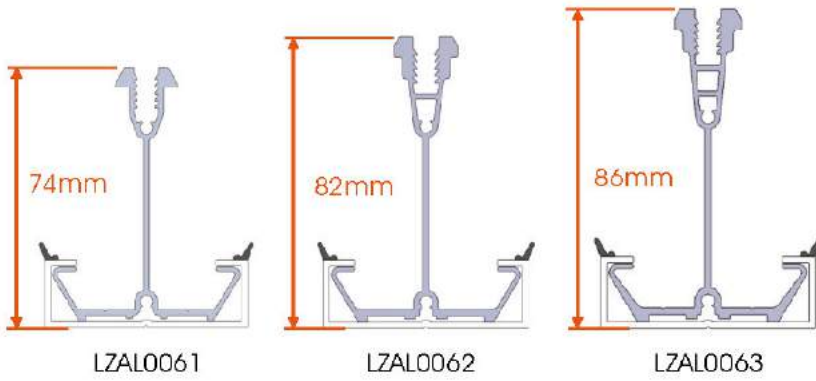

Transom bars may come preassembled with a bolster bar.

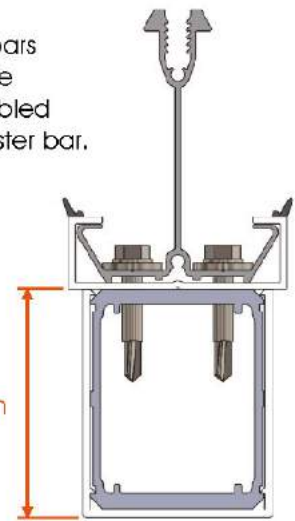

** Bottom caps may be square or ogee depending on order requirements **

Transom bars should be fitted with end cap mounting brackets in the correct orientation (see below) prior to installation. The transom bars can then be fitted. Each bar is secured by 4 x M6 flange nuts. This is on the eaves and wallplate / half ridge.

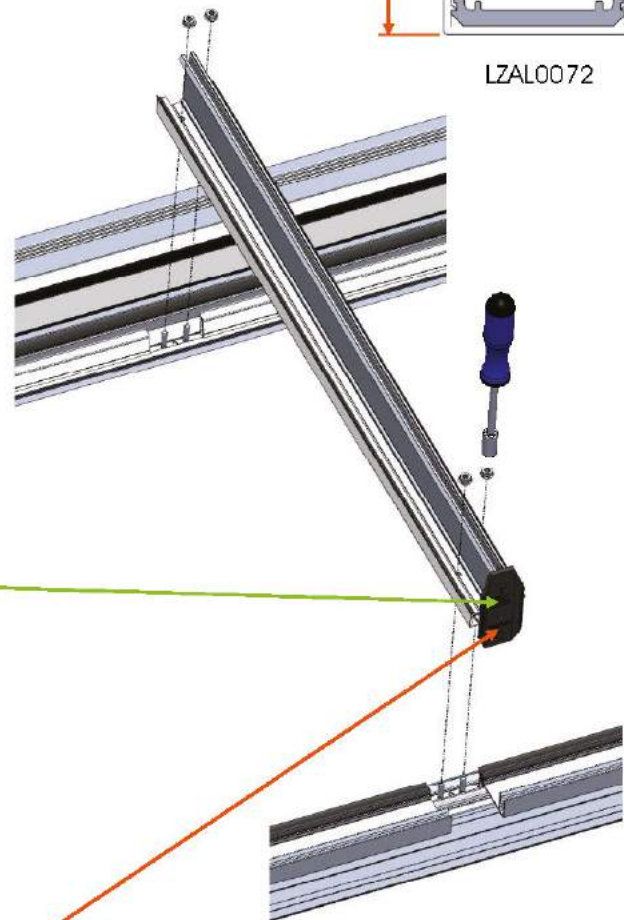

Standard Transom bars (LZAL0061)



HD & XHD Transom bars (LZAL0062/3)



Check the half ridge / wallplate is level once transom bars are fitted using a spirit level.

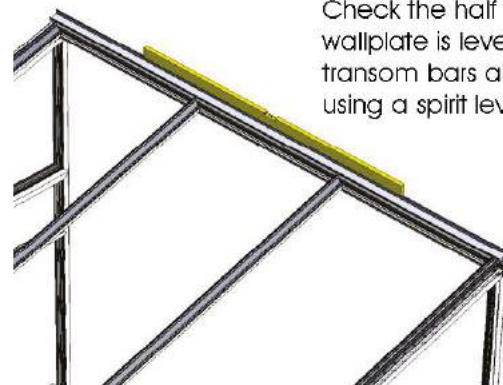

3.10 – Wallplate Top Cover Assembly

This section details fitting the wallplate top cover.

— Indicates where flashing will be needed. Chasing out of masonry and cleaning should be done before fitting top caps and glazing panels.



Related Components ...



LZPE0021



LZMP0017



LZMP0014



LZPE0047



If end bars are fitted

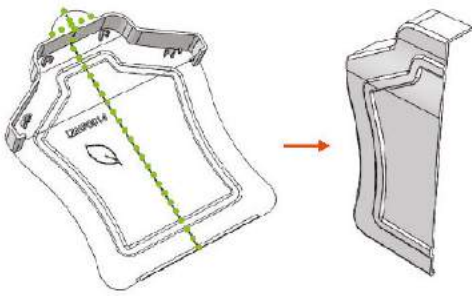

Cut down the gable end plate using the line down the back as a guide. Where a wallplate is used you will also need to cut the semi circular section off the top.

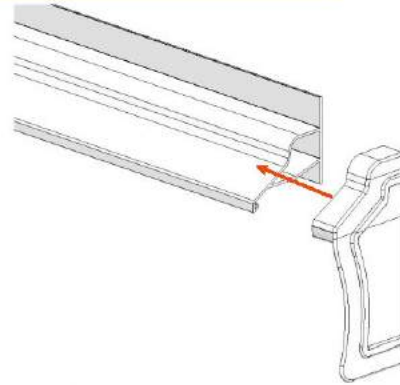

Apply an appropriate sealant to mating surfaces of the two components and then secure in place.

If wall bars are fitted

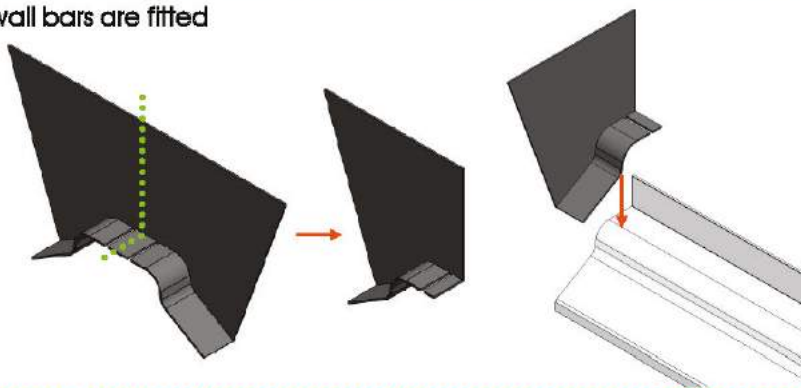

Cut the ridge flashing trim down the centre.

Apply an appropriate sealant to the mating surfaces of the two components and then secure in place.

Chase out mortar for flashing along the top of the wallplate, flashing trim and wall bars (where fitted), ensuring there is sufficient space to flash over the wallplate cover.

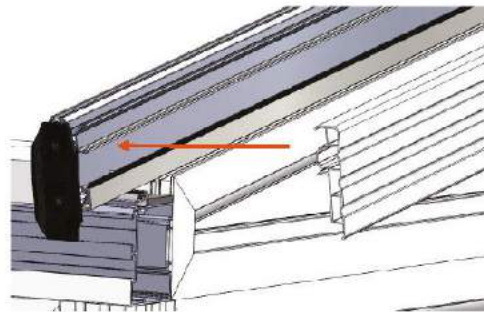

End Bar Cloak

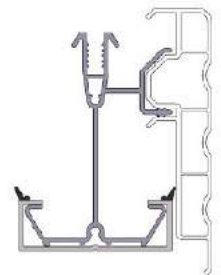

** Ensure that all dust and debris is cleaned from the roof assembly before fitting covers, trims and glazing **

Fit the end bar cloak to all end bars, butting the bottom edge of the end bar cloak up to the end cap mounting brackets at the bottom of the end bars.



Apply an appropriate seal in the groove run on the back of the end plate as shown.

Wallplate and Cover Assembly

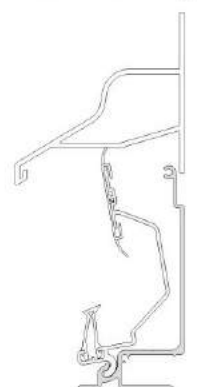

Position the wallplate cover against the wall and lower until it is sitting on the fascia trim. Where applicable push the cover into the corner of the two walls with the flashing trim against the end wall and end plate against the end bar cloak. Secure to the wall using preparatory fixings at approximately 600mm intervals. Wipe away any excess sealant around the end plate.

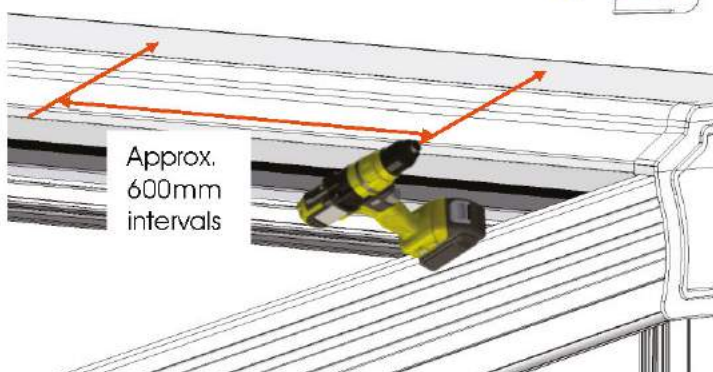

3.11 – Half Ridge Cover Assembly

This section details fitting the half ridge top cover.

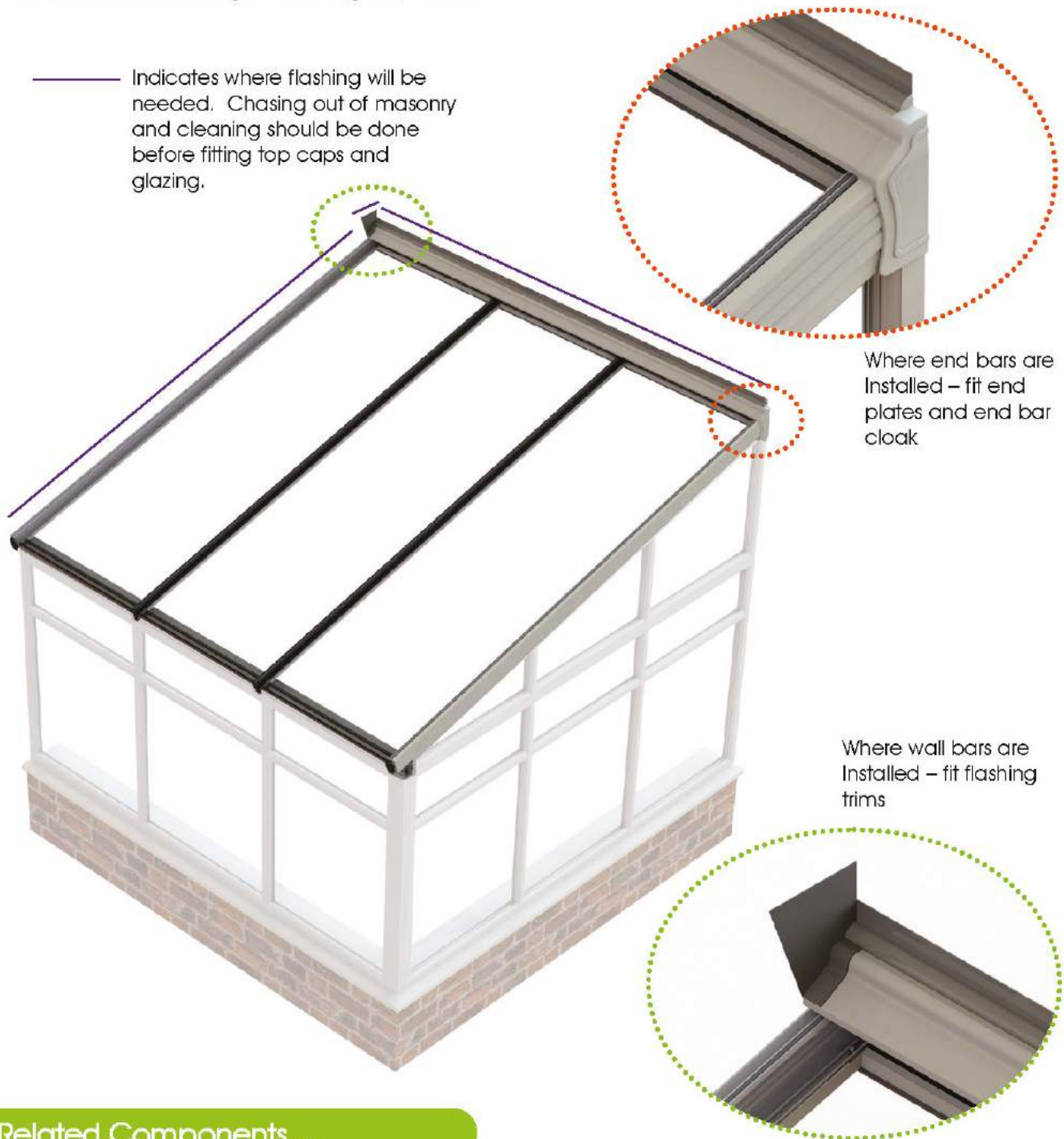

Related Components ...



LZPE0011



LZPE0050



LZMP0017



LZMP0014



LZPE0047



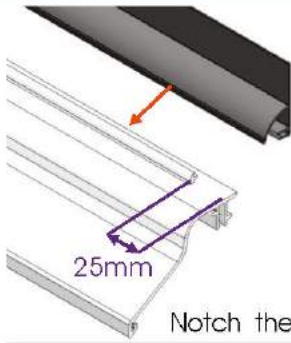

Notch the half ridge cover on the end bar side to allow for the gable end plate.

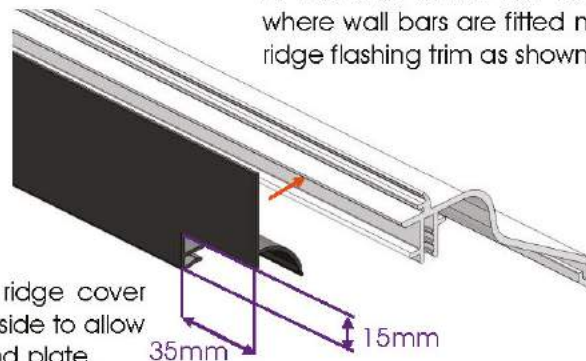

At the ends of the half ridge cover where wall bars are fitted notch half ridge flashing trim as shown.

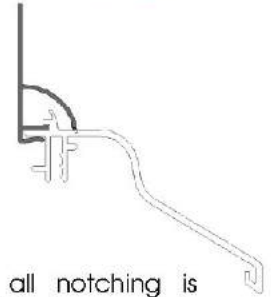

Once all notching is completed, assemble the half ridge cover and flashing trim.

If end bars are fitted

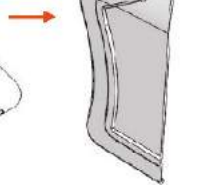
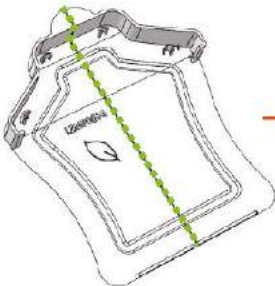

Cut down gable end plate using the line down the back as a guide.

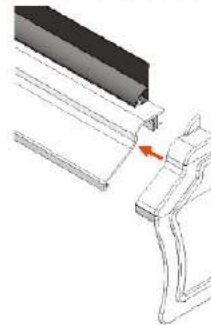

Apply an appropriate sealant to mating surfaces of the two components and then secure in place.

If wall bars are fitted

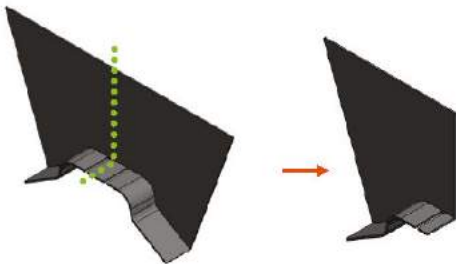

Cut the ridge flashing trim down the centre.

Apply appropriate sealant to the mating surfaces of the two components and then secure in place.

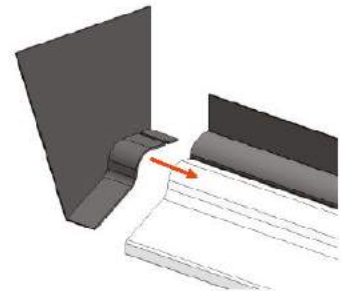

Chase out mortar for flashing along the top of the half ridge, flashing trim and wall bars (where fitted), ensuring there is sufficient space to flash over the half ridge cover.

** Ensure that all dust and debris is cleaned from the roof assembly before fitting covers, trims and glazing **

Fit the end bar cloak to all end bars, butting the bottom edge of the end bar cloak up to the end cap mounting brackets at the bottom of the end bars.

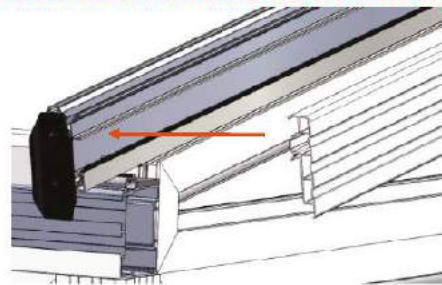

End bar cloak

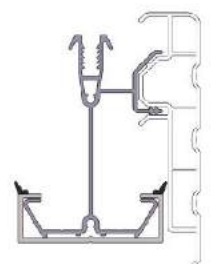

Half ridge and cover assembly

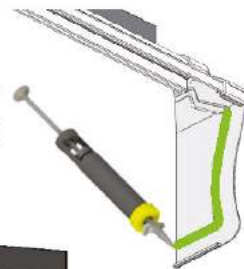

Apply an appropriate sealant in the groove run on the back of the end plate as shown.

Place the cover assembly on top of the half ridge and clip in place. Where applicable, push the cover into the corner of the two walls with the flashing trim against the end wall and end plate against the end bar cloak. Wipe away any excess sealant around end plate.



3.12 – Wallplate / Half Ridge / Wall Bar Flashing

This section details flashing along the length of wallplate, half ridge and wall bars.



Related Components ...



** Lead flashing is not provided with the roof kit **



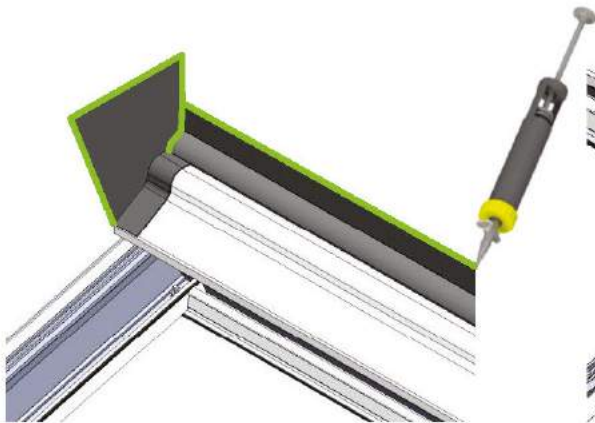

Apply a continuous bead of appropriate sealant along the top edge of the flashing trim and wallplate covers.



Apply a continuous bead of sealant along the edge of the end plate where it meets the wall.

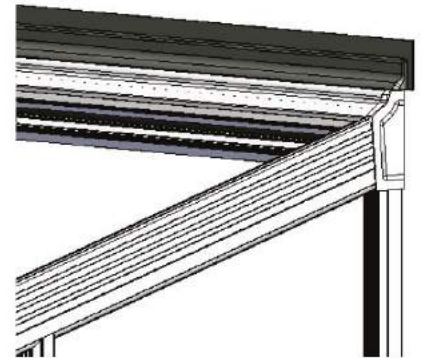

Fit flashing along the top cover.

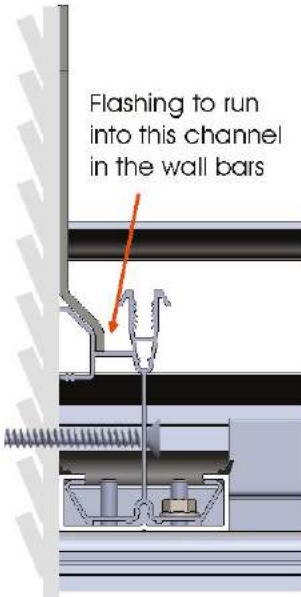

Flashing to run into this channel in the wall bars

Where wall bars are used, fit the flashing along the length of the wall bar. Run the flashing into the channel shown. The final piece of flashing will cover the ridge flashing trim in the corner as below.

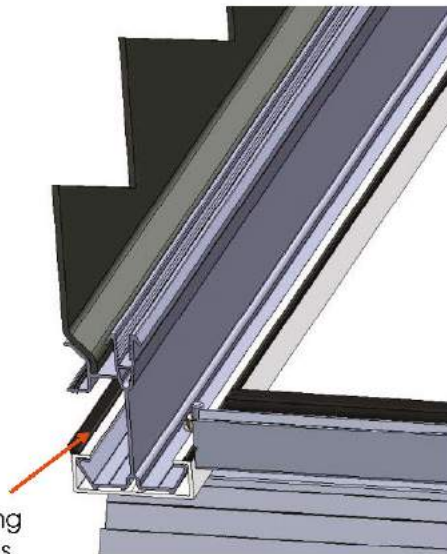

(Note: End cap mounting bracket not shown in this image)

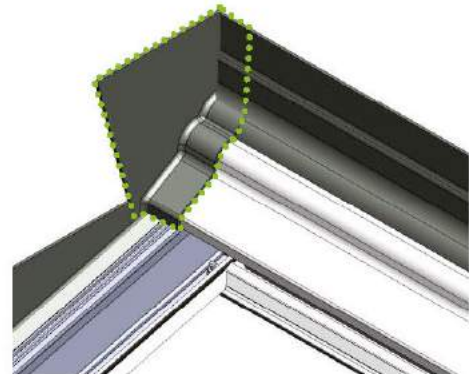

LZPE0008
Square bottom cap

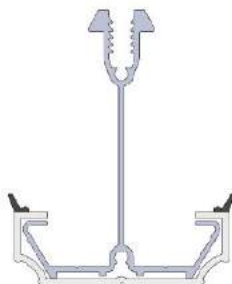

LZPE0007
Ogee bottom cap

Use appropriate sealant between all roof bars and glazing retainers..

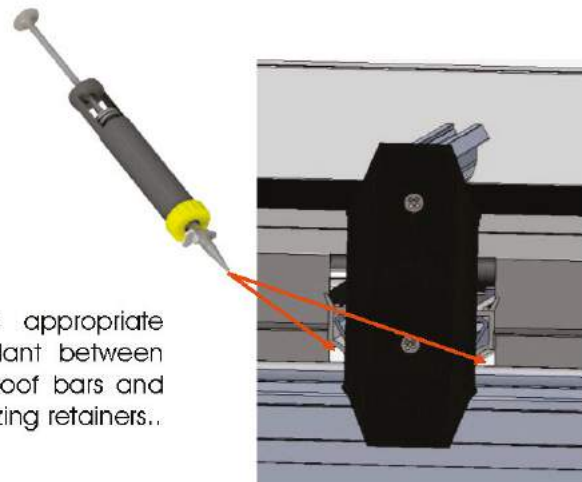

3.13 – Glazing Assembly

This section shows the installation of glazing panels and glazing retainer trims.

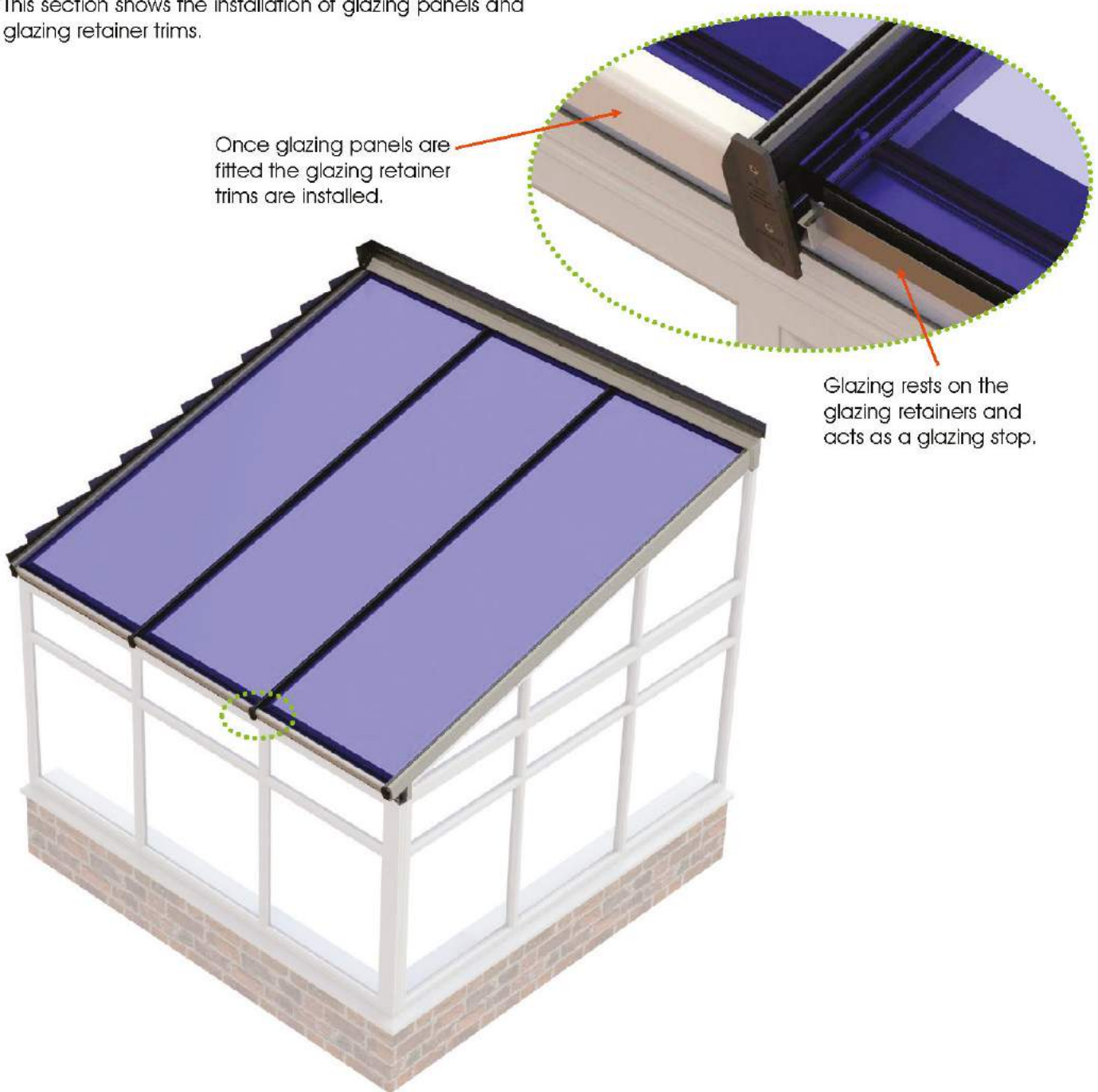

Related Components ...

-  24mm Glazing (Typically glass)
-  25mm Glazing (Typically polycarbonate)
-  32mm Glazing (Typically polycarbonate)



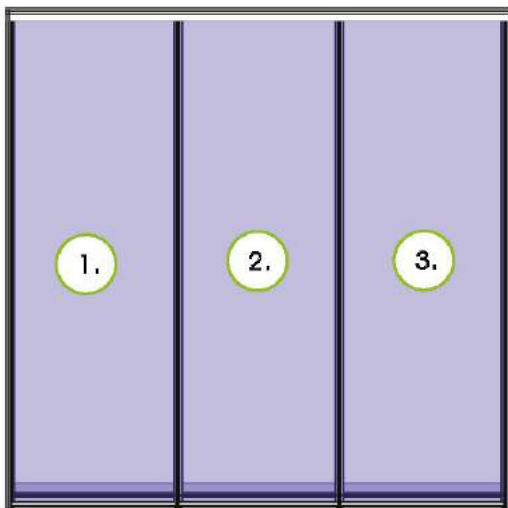

Fit the glazing in the order as shown, working from one end of the roof to the other.

- A.** To install the glazing, push the top end of the glazing panel into the gap between the two black gaskets along the wallplate / half ridge with the bottom end elevated.
- B.** Then lower the bottom end of the glazing panel to rest on the roof bars.
- C.** Finally slide the glazing down until it is resting on the glazing retainer.

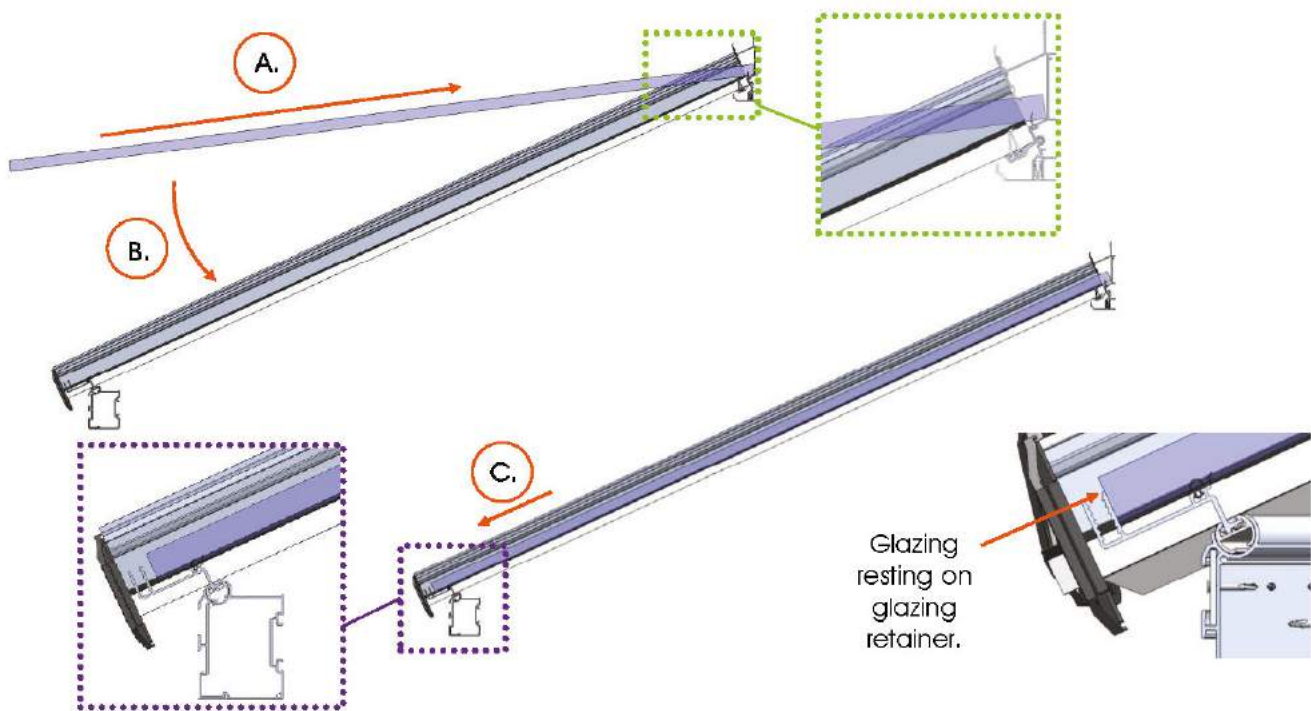

Once the glazing is in position, the glazing retainer trims should then be inserted into the aluminium glazing retainers.

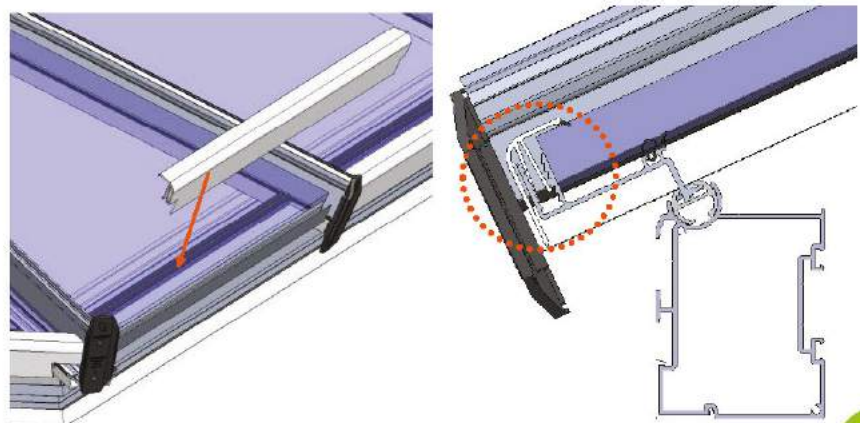

** Glazing retainer trims must be fitted before the transom/wall/end top caps are installed **

3.14 – Roof Bar Top Cap Assembly

This section details fitting the roof bar top caps.



Related Components ...



LZPE0041



LZPE0042



LZPE0043



LZPE0045



LZPE0046



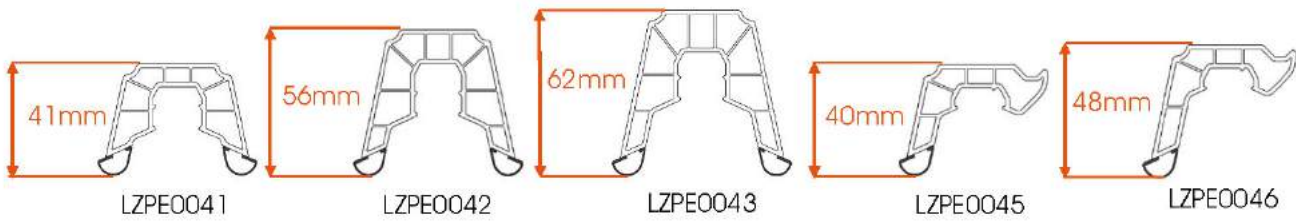

When fitted, all top caps should be in contact with the end cap mounting brackets at the bottom of each roof bar.

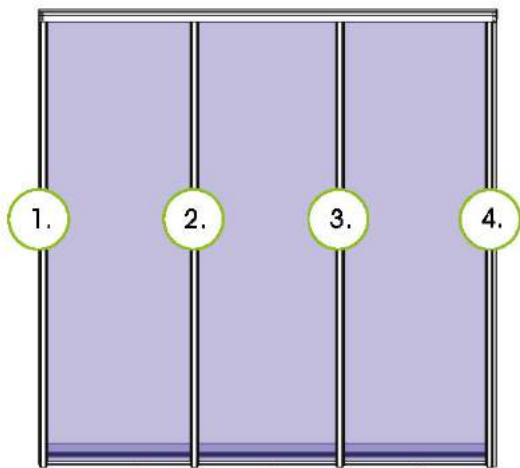

Ensure glazing retainer trims are fitted before top caps

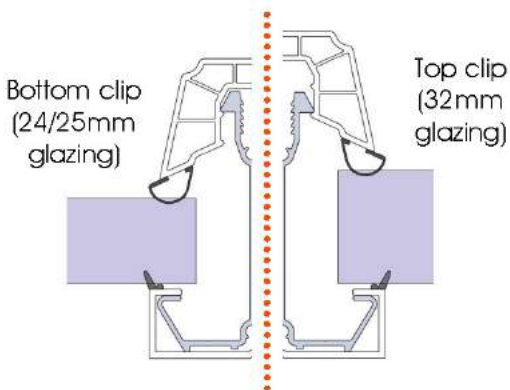
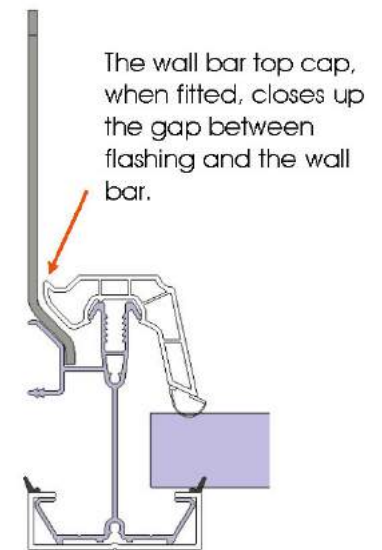
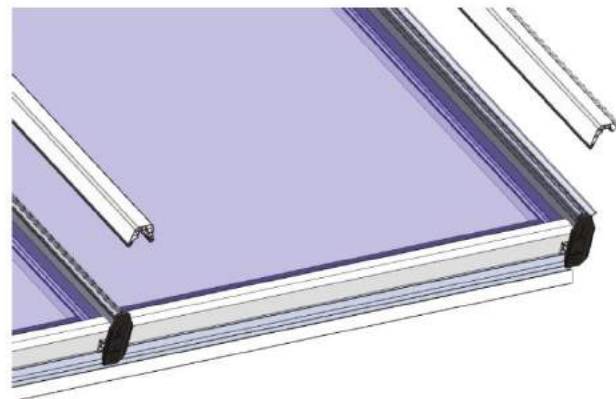

To fit the end bar top caps, first insert under the lip of the end bar cloak (1). Then rotate the gasket down towards the glazing and clip into position (2).

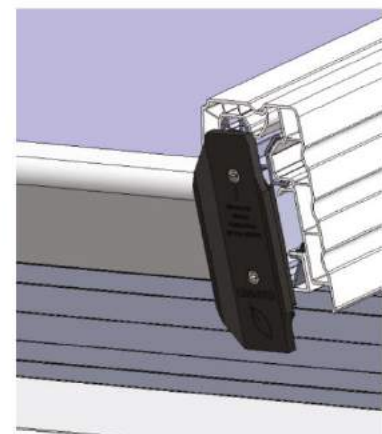
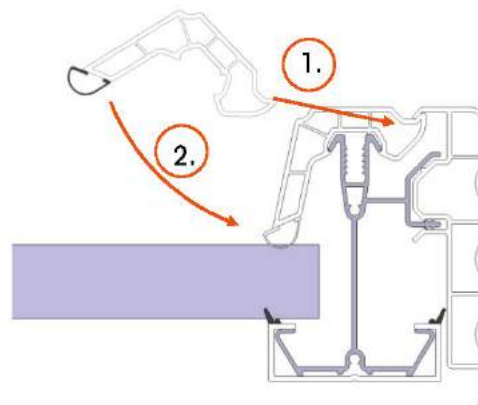

3.15 - Roof Bar End Caps

The roof bar end caps are installed to the ends of all bars. Ensure the end cap mounting brackets are present as the caps slide onto them.

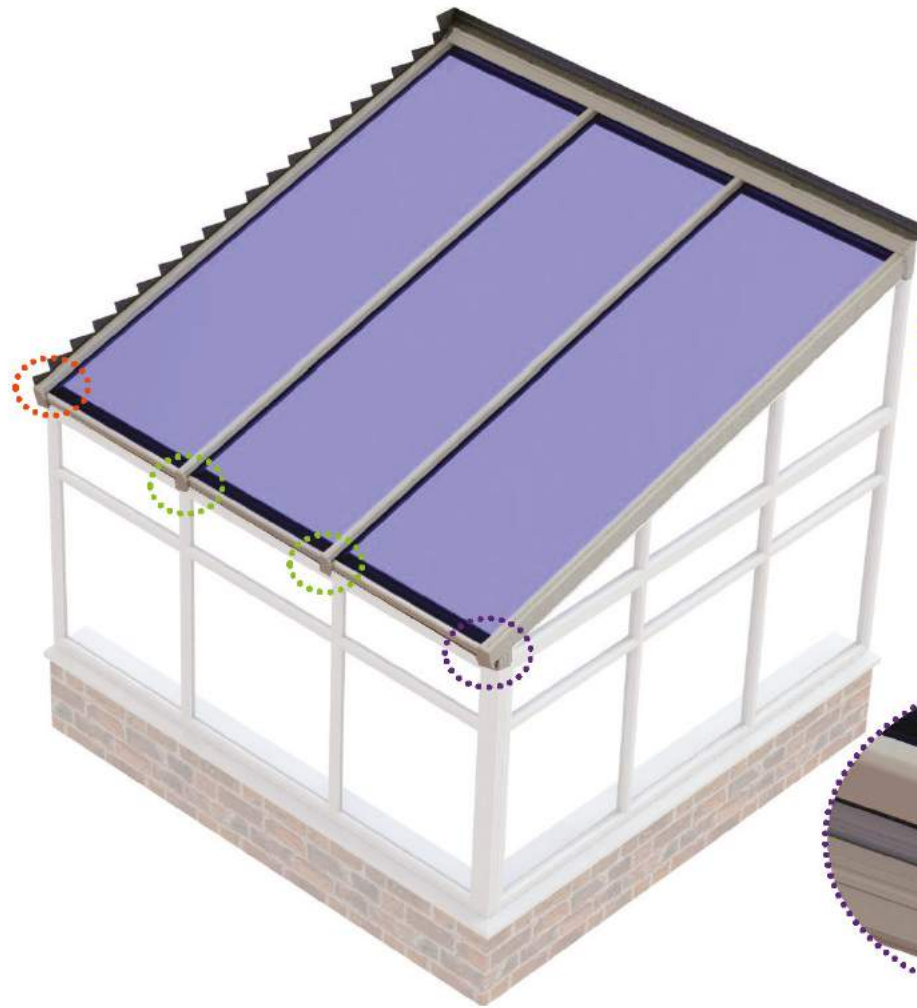

Wall bar end caps



Transom bar end caps



End bar and eaves beam end caps

Related Components ...



LZMP0053



LZMP0051



LZMP0054



LZMP0055



LZMP0056



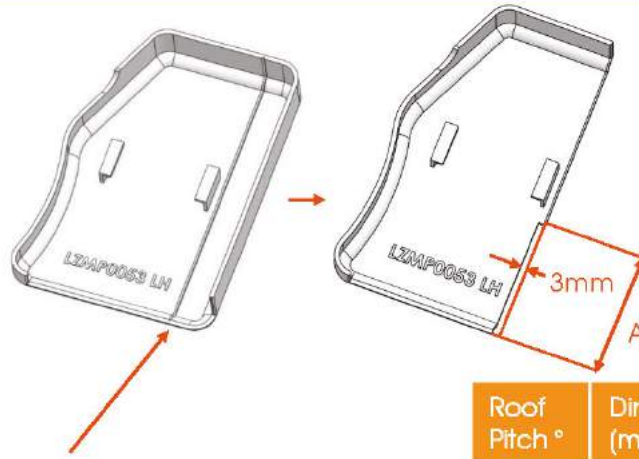
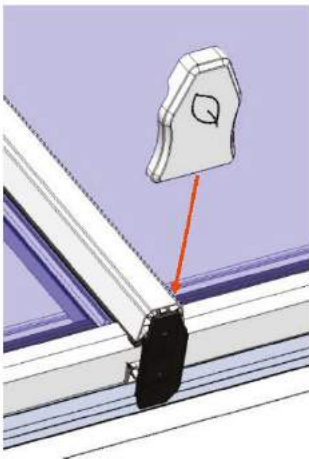

Wall/end bar caps (LZMP0053/4) can be used in two applications. Either capping the wall bar or capping an end bar on a gable / lean to. If being used for the wall end side they must be cut down along the guideline indicated above and then notched as per the table.

All other bars use the roof bar end caps (LZMP0052). The diagram below shows the correct positioning.

Roof Pitch °	Dim A (mm)	Roof Pitch °	Dim A (mm)
5	25.0	23	52.0
6	26.5	24	53.5
7	28.0	25	55.0
8	29.5	26	57.0
9	31.0	27	58.5
10	32.5	28	60.0
11	34.0	29	62.0
12	35.0	30	64.0
13	36.5	31	66.0
14	38.0	32	67.5
15	39.5	33	70.0
16	41.0	34	71.5
17	42.5	35	74.5
18	44.0	36	76.5
19	45.5	37	78.5
20	47.0	38	81.0
21	48.5	39	83.0
22	50.0	40	85.5

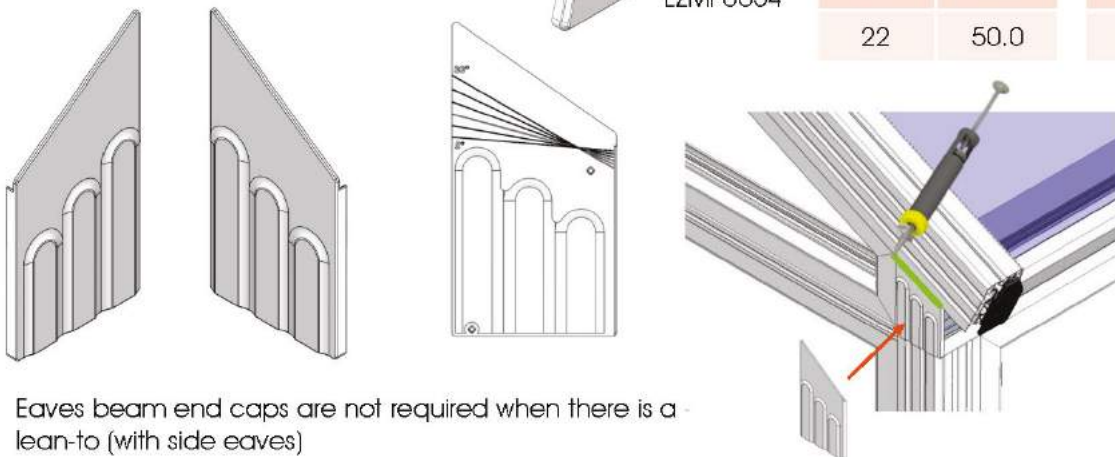
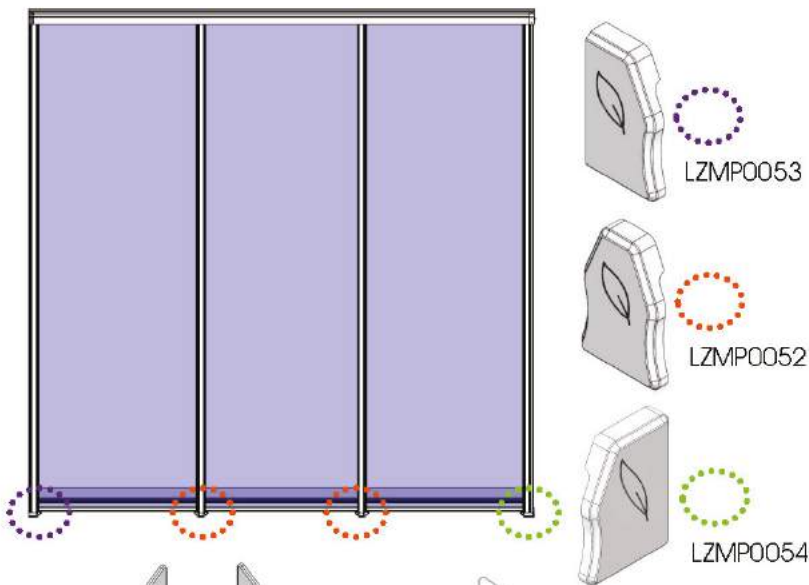

Eaves beam end caps are not required when there is a lean-to (with side eaves)

Eaves beam end caps should be cut down to the appropriate angle to match the pitch of the roof. Guide markers on the back of the caps show where to cut. The caps can then be inserted into the end of the eaves beam and a bead of appropriate sealant should be run along the top edge of the cap.

3.16 – Internal Eaves/Ridge Trims Assembly

Internal trims are fitted to the eaves beams and on the underside of the wallplate / half ridge.

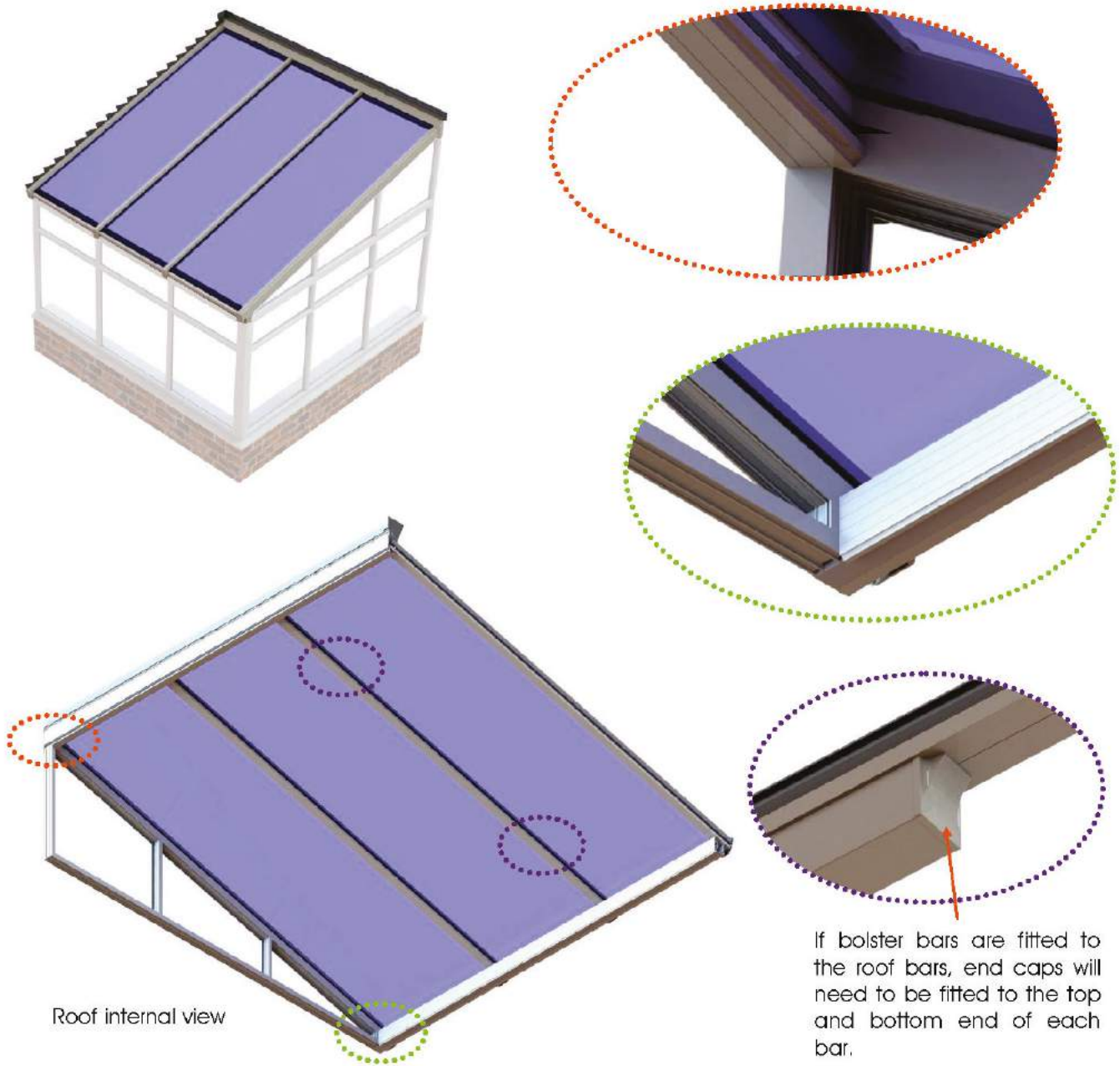

Related Components ...



LZPE0010



LZMP0001



(for half ridge)



(for wallplate)



LZMP0072



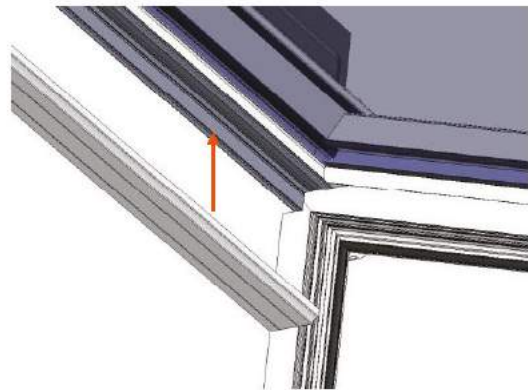
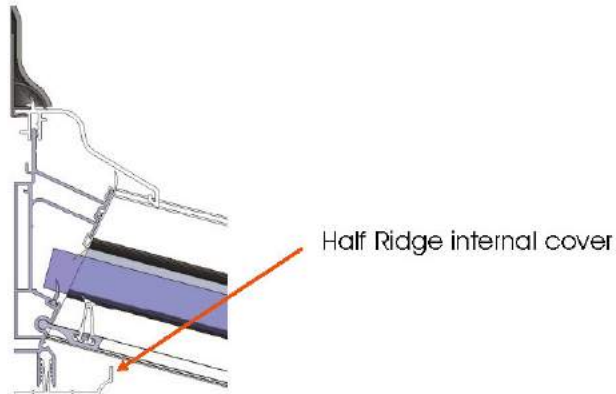
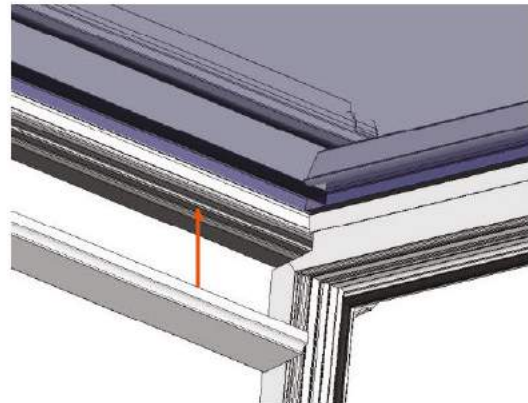
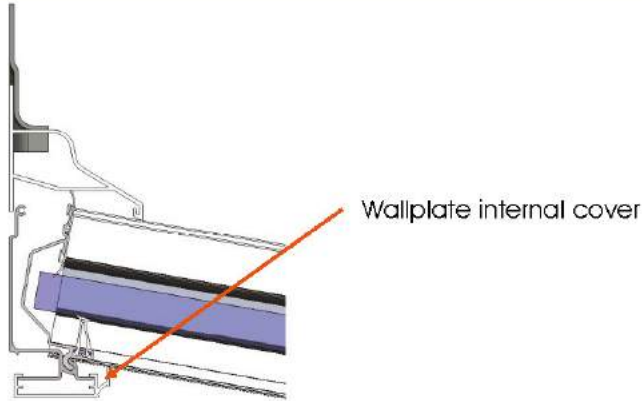

If a lean-to with side eaves, fit the eaves beam cloak joint covers.

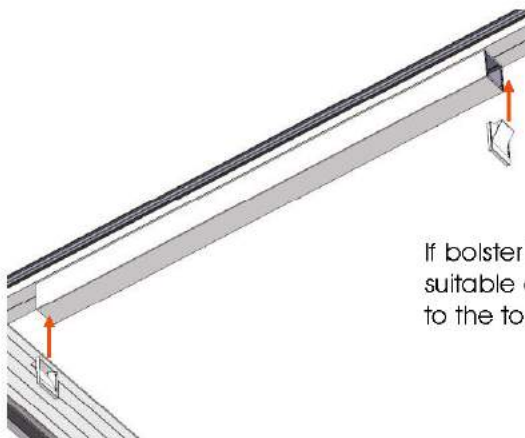
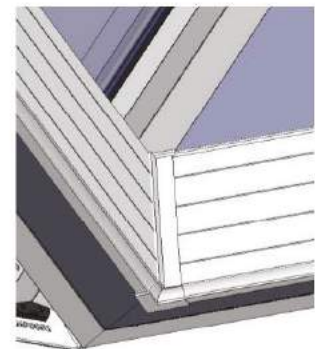
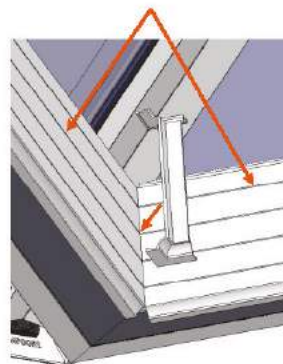
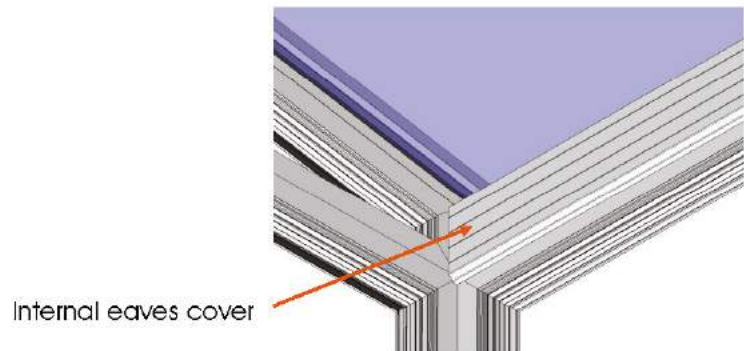

If bolster bars are fitted to the roof, use a suitable adhesive to secure the end cap to the top and bottom of each bolster bar.



4.00 – Hipped Lean To Assembly

This section details the assembly of hipped lean-to roofs. As many of the assembly steps are common to other mono pitch roofs, this section makes reference to pages from section 3.0 in this installation manual where assembly information has already been detailed.



Installation Steps...



Preparation
Section 3.00,
pages 6-7



**Scribing Half Ridge /
Wallplate Position**
Section 3.01,
pages 8-9



Eaves Beam Assembly
Section 3.02,
pages 10-11



**Raked Frame Notching /
Assembly**
Section 3.03, pages 12-13
Section 3.04, pages 14-15



Glazing Retainer Assembly
Section 3.05,
pages 14-17



Wallplate / Half Ridge Assembly
Section 3.03,
pages 12-13



Wall / End Bar Assembly
Section 3.08,
pages 22-23



Hipped Wall Bar Assembly
Section 5.02,
pages 42-43



Hip Bar Assembly
Section 5.03,
pages 44-45



Transom Bar Assembly
Section 3.09,
pages 24-25



Jack Rafter Assembly
Section 5.04,
pages 46-47



Wall Bar Flashing
Section 5.05,
pages 48-49



Glazing Assembly 1
Section 5.06, pages 50-51
Section 3.13, pages 32-33
Section 3.14, pages 34-35



Weather Seal Assembly
Section 5.07,
pages 52-53



Wallplate / Half Ridge Cover Assembly and Flashing
Section 5.08,
pages 54-55



Glazing Assembly 2
Section 3.08, pages 32-33
Section 3.14, pages 34-35



Roof Bar End Caps
Section 3.15,
pages 36-37



Internal Eaves / Ridge Trims / Cover Assembly
Section 5.10, pages 56-57
Section 3.16, pages 38-39



Guttering Assembly
Section 6.00,
pages 56-57

5.02 – Hipped Lean To – Hipped Wall Bar Assembly

When a wall bar is used on a hip end of a roof, it is connected to the D-ring and is known as a hipped wall bar.



Related Components ...



Hipped Wall Bar Assembly



LZFX0018



LZFX0020



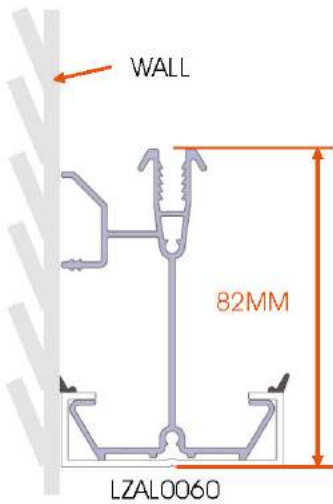

End cap mounting bracket (LZMP0051)



Ensure the end cap mounting bracket is in the correct orientation (see image above) and installed to the bars prior to fitting.

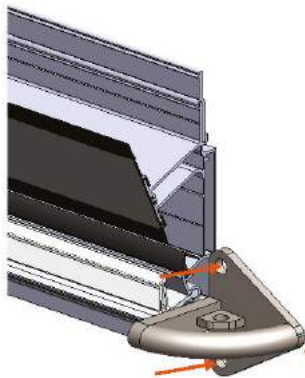

The D-ring connector will be pre-set to the correct angle to suit the roof pitch

It is recommended that the half D-ring is secured to the wall through the two fixings holes, using appropriate proprietary fixings.

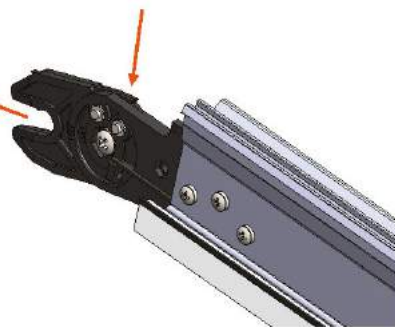

Connect the top end of the hipped wall bars to the half D-ring at the end of the wallplate / half ridge by pushing the connector, whilst levering the bar up and down until it clicks into place.



The hipped wall bar is fixed in place with 1x M6 flange nut at the eaves

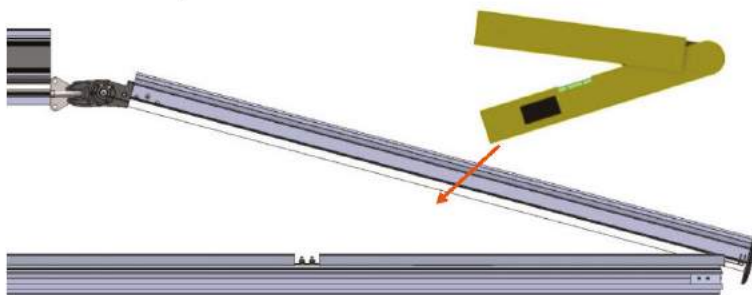

Once fixed in place, use an angle finder to check the wall bars are set at the correct angle.

Secure the hipped wall bar to the wall using appropriate proprietary fixings at 600mm centres and 150mm from the ends of bars (see section 3.08, pages 22-23).

5.03 – Hipped Lean To –Hip Bar Assembly

Installation of hip bars.

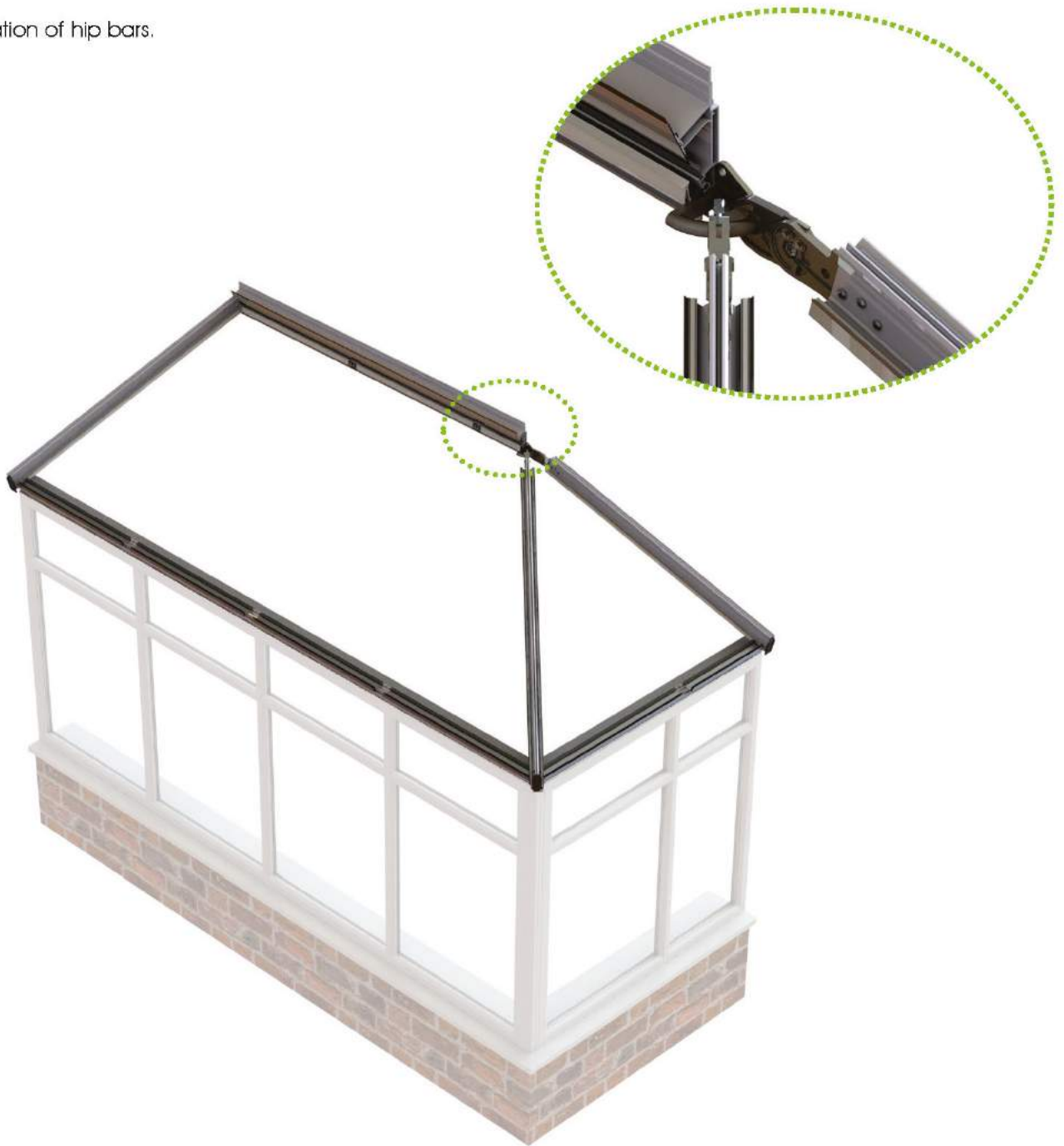

Related Components ...



Hip
Assembly



LZFX0001



LZFX0018



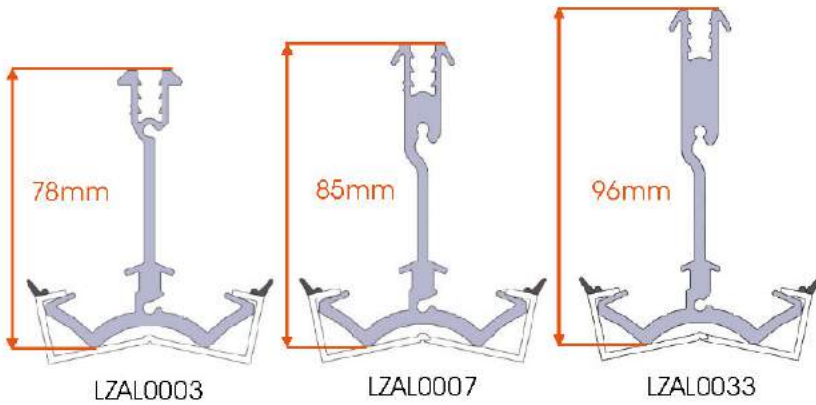

See page 23 for bolster bar dimensions



Arrow Down



The d-ring connector will be pre-set to the correct angle to suit the roof pitch

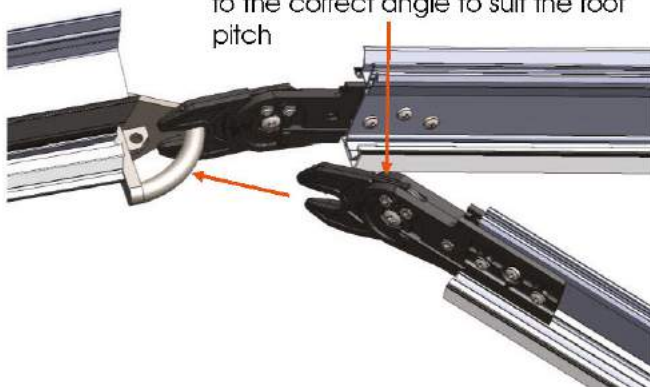

Hip bars should be fitted with end cap mounting brackets in the correct orientation (see above) prior to installation.

** Hand tighten. Do not use an impact driver **

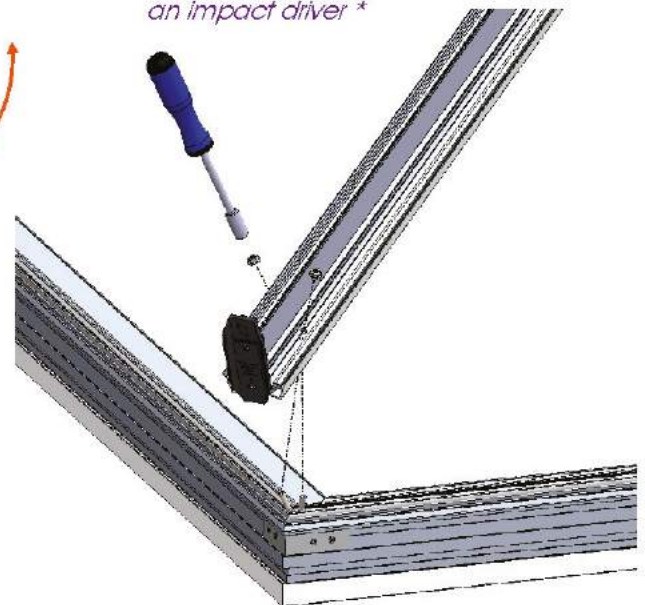

Connect the top end of the hip bars to the d-ring at the end of the wallplate / half ridge by pushing the connector, whilst levering the bar up and down until it clicks into place.

Connect the bottom end of the hip bar to the eaves beam securing it in place with 2 x M6 flange nuts.

Align the d-ring connectors with the centre point of the half d-ring (shown below).

Once bars are positioned, tighten the grub screw to lock the d-ring connector in place with a 2.5mm Allen Key.

** In some instances it may be necessary to remove the D-Ring connector from hipped wall bars in order to fit the hip bars **

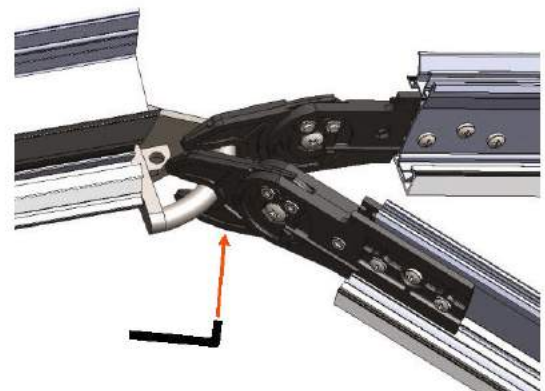
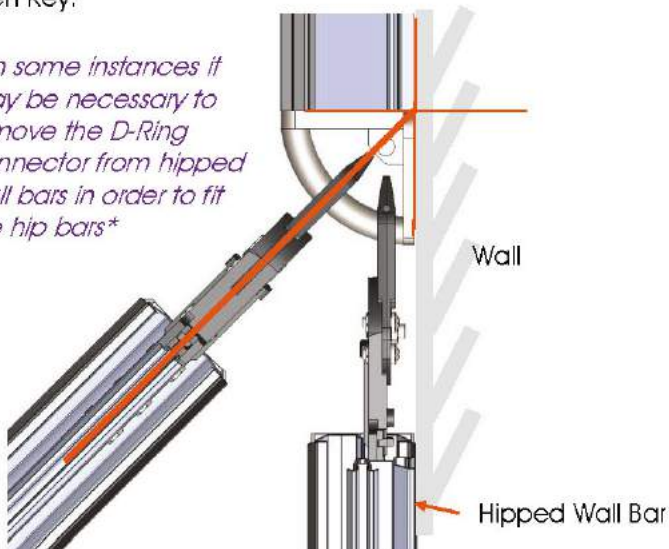

5.04 – Hipped Lean To – Jack Rafter Assembly

A jack rafter is a bar that connects to a hip bar.

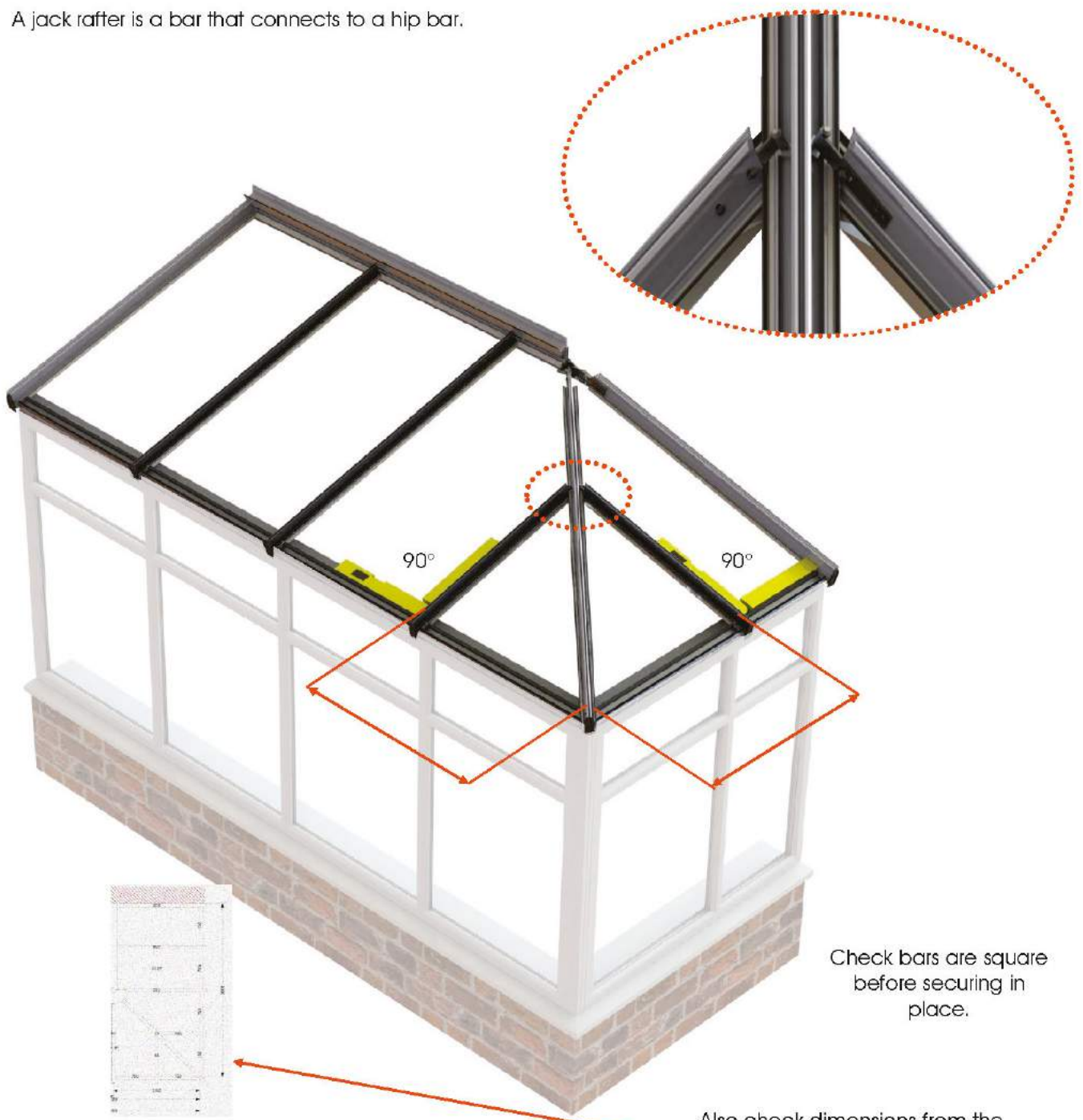

Check bars are square before securing in place.

Also check dimensions from the paperwork for the positioning of the bars

Related Components ...



Jack Rafter Assembly



LZFX0020



LZFX0018



Jack rafters should be fitted with end cap mounting brackets in the correct orientation (see below) prior to installation.



Standard jack rafter bars (LZAL0061)



HD & XHD jack rafter bars (LZAL0062/3)

The arm allows full adjustment

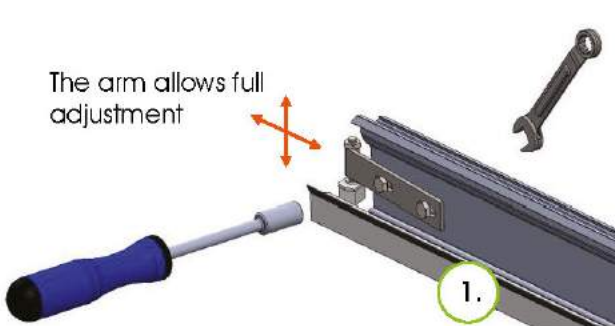

1. Slacken nuts on jack rafter arms enough to allow for adjustment during assembly. ** Note do not remove nuts **

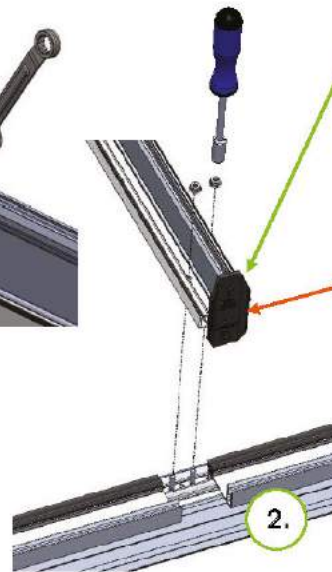

2. Fix bottom of jack rafter in position on eaves beams using 2 x M6 flange nuts.

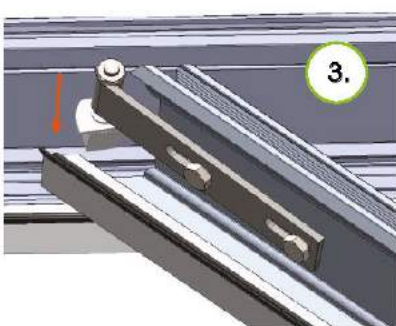

3. Insert jack rafter fixing into channel of the hip bar, compressing the foam pad on the bottom and then rotate to hold in place in the channel (4).

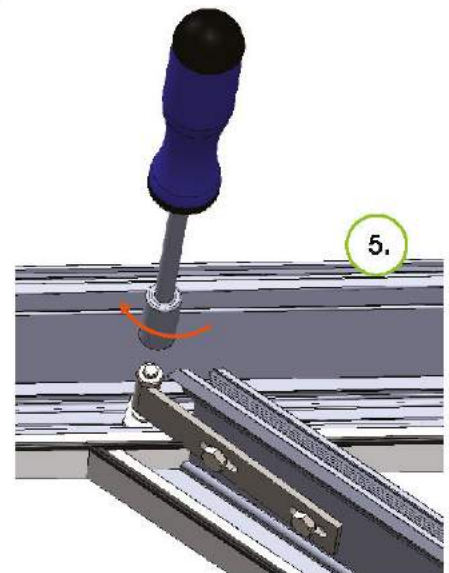
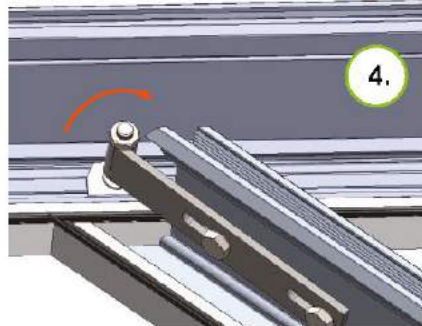

5. Tighten the M6 nut on top of the jack rafter arm to lock it into the hip bar.

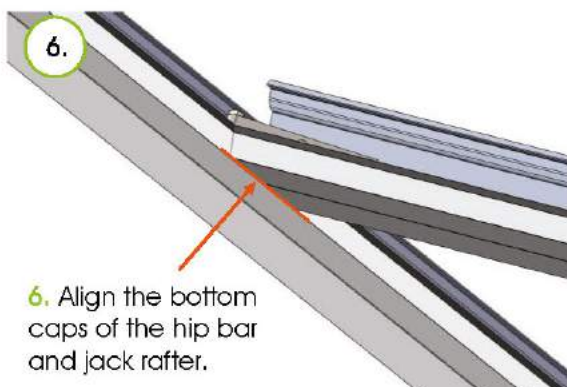

6. Align the bottom caps of the hip bar and jack rafter.

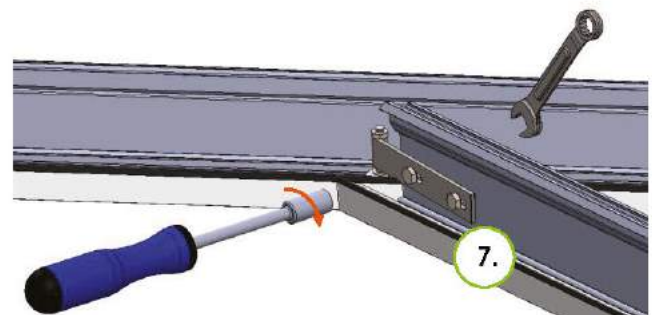

7. Lock off fixings on jack rafter

5.05 – Hipped Lean To –Wall Bar Flashing

At this point the walls should be chased out for all flashing to be fitted. The flashing can then be fitted for wall bars and hipped wall bars. All other flashing will be fitted once wallplate or half ridge top covers are fitted.



Related Components ...



** Lead flashing is not provided with the roof kit **

— Indicates where flashing will be needed. Chasing out of masonry and cleaning should be done before fitting top caps and glazing.

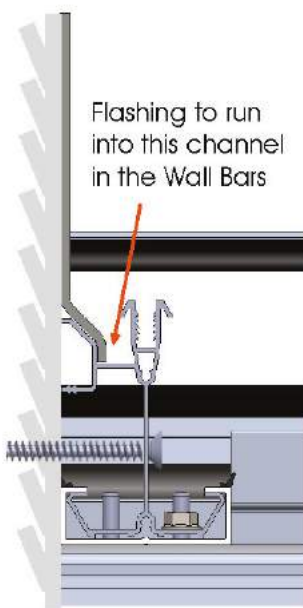
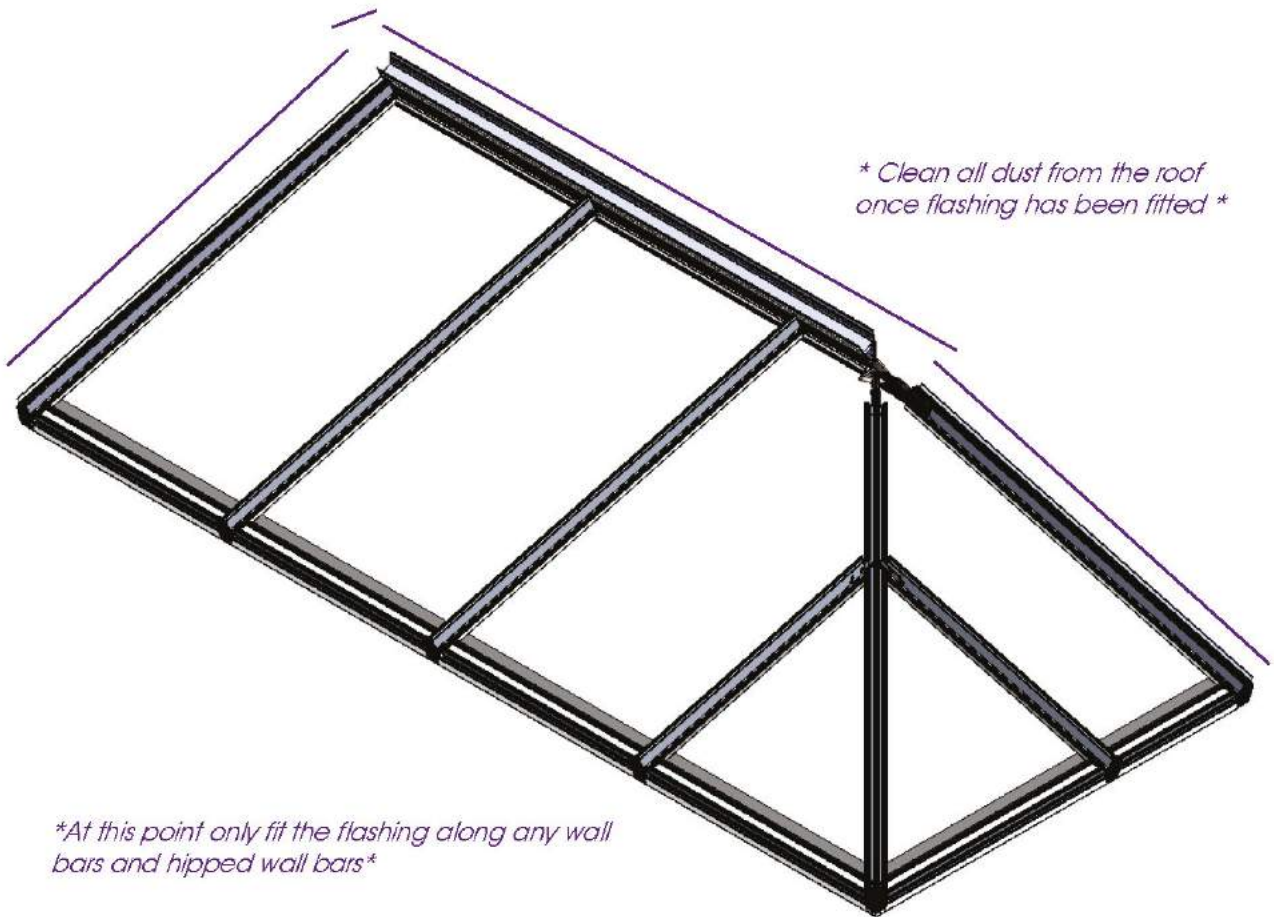

Where wall bars and hipped wall bars are used fit the flashing along the length of the bar running the flashing into the channel shown.

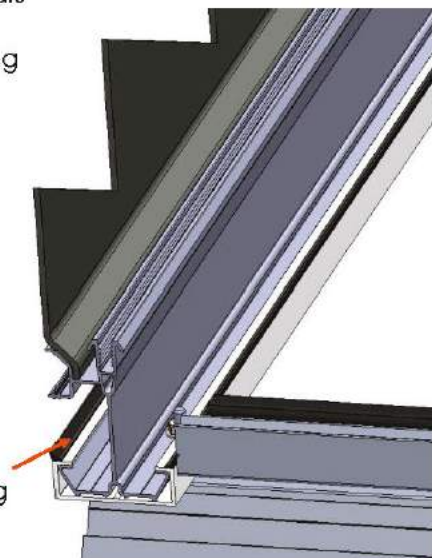

5.06 – Hipped Lean To –Glazing Assembly 1

The roof is only partially glazed at this point as you will need access to the wallplate / half ridge. Glazing panels should be installed up to the closest transom bars to the half D-ring. This is to allow access to the half D-ring area for sealing.



Related Components ...

- 24mm Glazing
 - 25mm Glazing
 - 32mm Glazing
-  LZPE0028

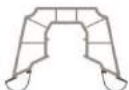
 LZPE0041

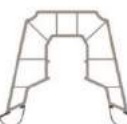
 LZPE0042

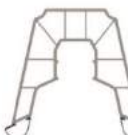
 LZPE0043

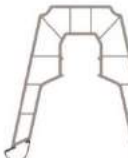
 LZPE0044

 LZPE0045

 LZPE0046

Fit glazing panels and glazing retainer trims (see section 3.13, pages 30-31 for more details)

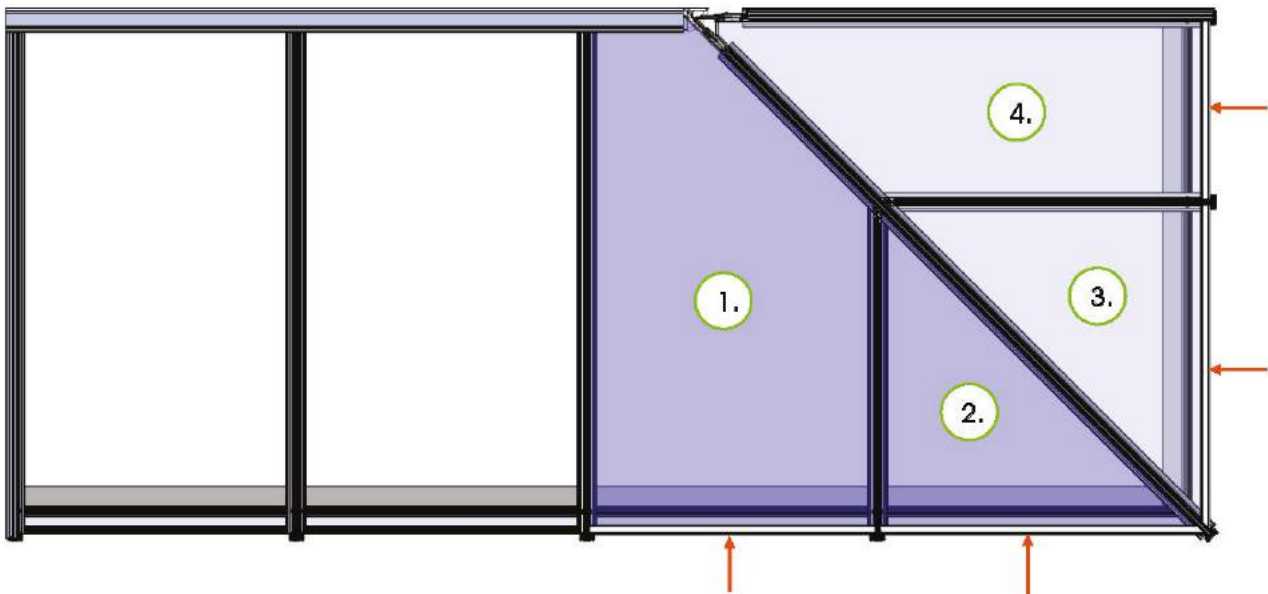

Fit top caps (see section 3.14, pages 32-33 for more details)

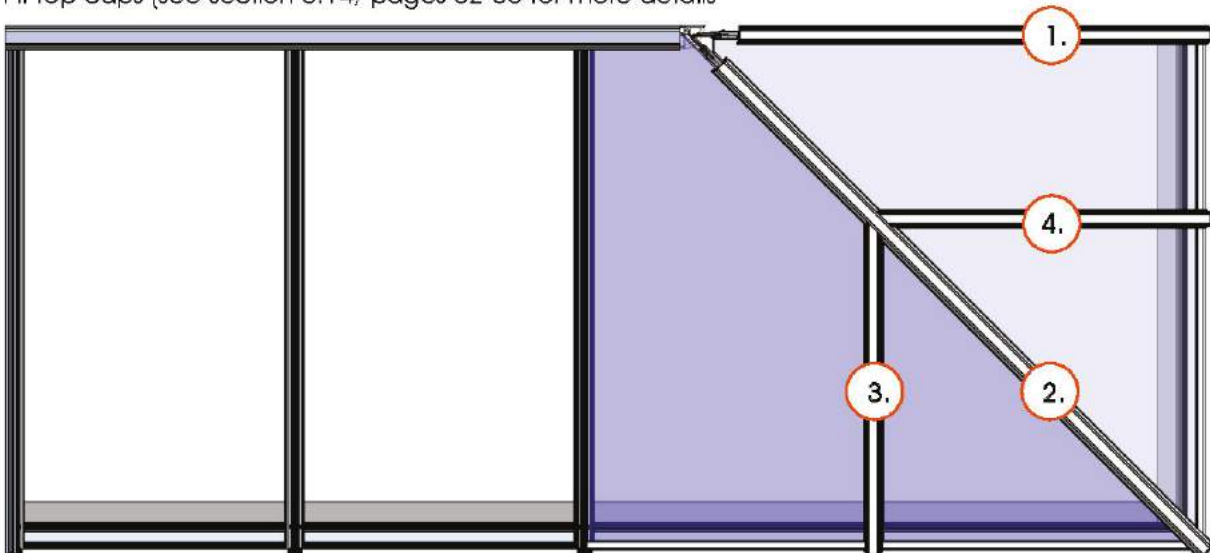

Fit top caps in the sequence shown. Top caps should be fitted to the hip bars prior to the jack rafters. This is due to the jack rafter top caps butting up the hip cap once in position. (See top cap assembly above)

The top end of the jack rafter top caps have compound cuts which match the angle of the hip bar top caps.

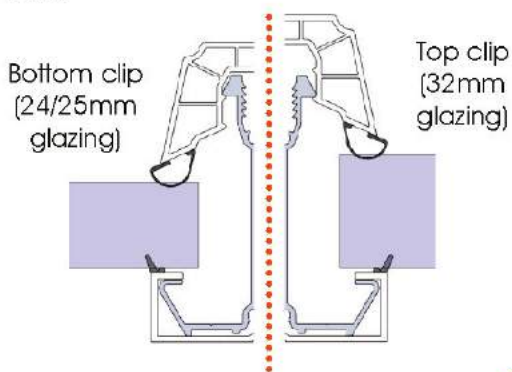

Apply an appropriate sealant to the joint between the jack rafter and hip top caps.

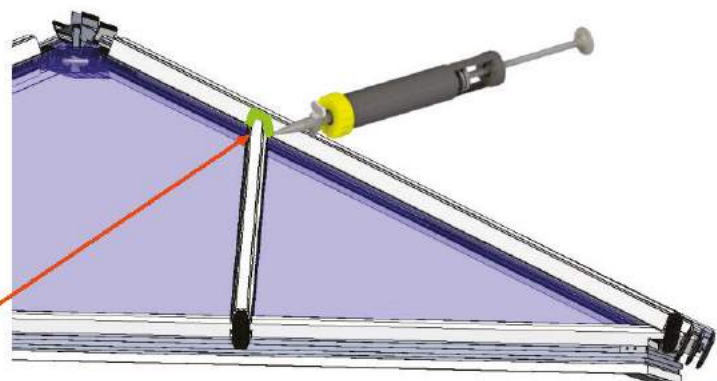

5.07 – Hipped Lean To – Weather Seal Assembly

This section shows how to install the weather seal which is positioned at the end of the wallplate / half ridge.

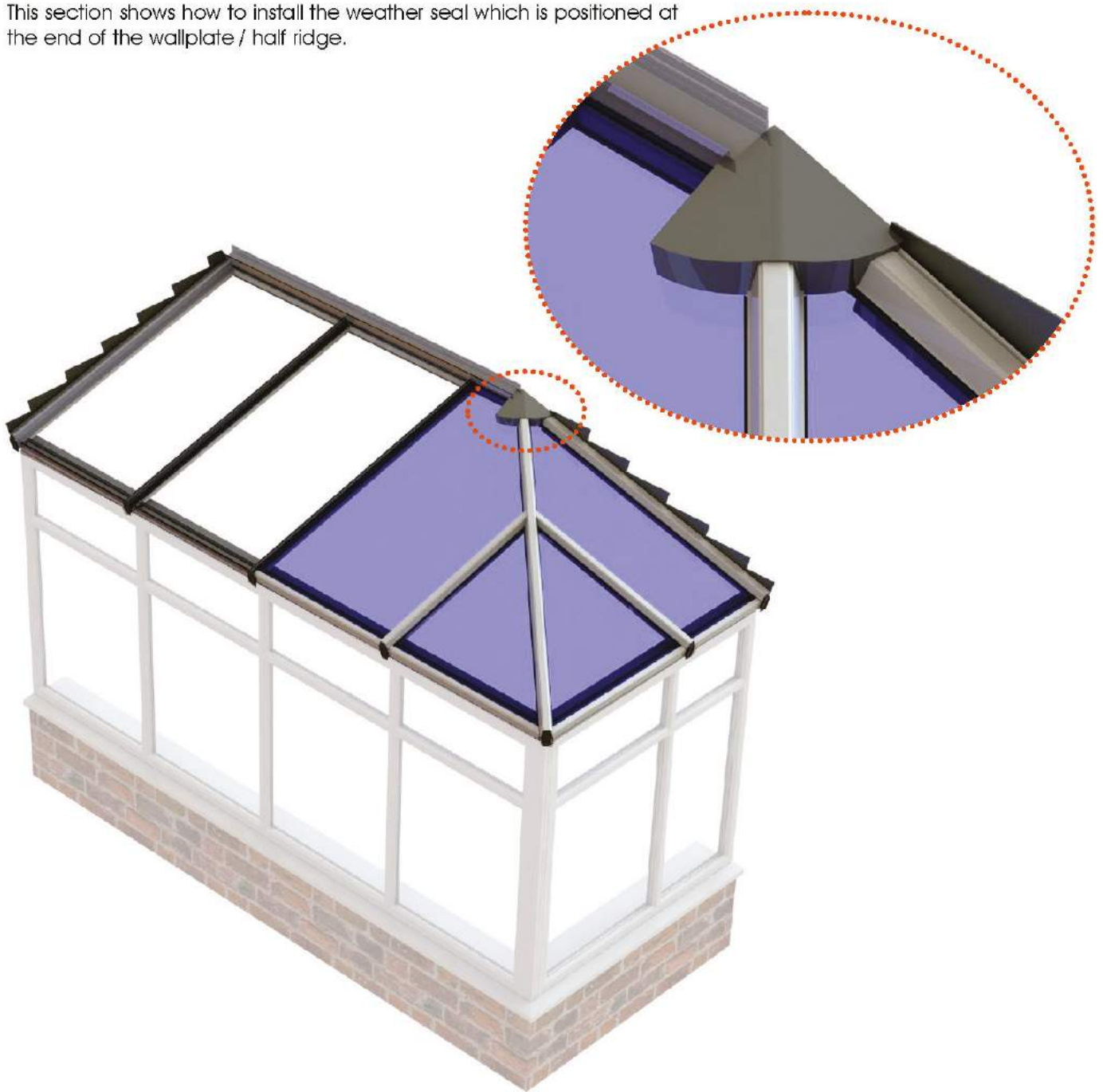

Related Components ...



LZSU0051/2



LZSU0066



The foam weather seal is made up from two foam weather seal bungs (LZSU0051 for LH and LZSU0052 for RH) and the foam weather seal mask (LZSU0066).

First remove the adhesive backing from one of the foam weather seal bungs and stick it to the second bung.

Then remove the backing from the piece of the weather seal mask and adhere around the edges of the assembled bungs, aligning the bottom edges, as shown below. You may need to trim the weather seal mask down to cloak the perimeter of the bung assembly.

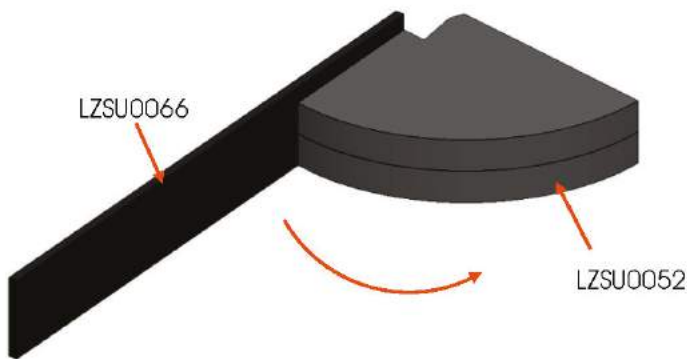

Foam Weather Seal Bung Assembly RH

Remove the backing tape from the bottom foam bung and stick over the exposed half d-ring area to create a weather tight joint. The weather seal will conform to the pitch of the roof and adhere to the glazing. The edges should be pushed up tight to the end of the hip bar top caps, the wall and the end of the wallplate / half ridge.

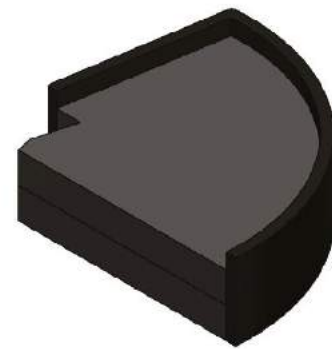

Foam Weather Seal Bung Assembly LH

Once in position, seal along the ends of the hip bar top caps, the edge of the weather seal that is in contact with the wall and the edge of the fascia trim on the wallplate / half ridge. Seal using an appropriate sealant.

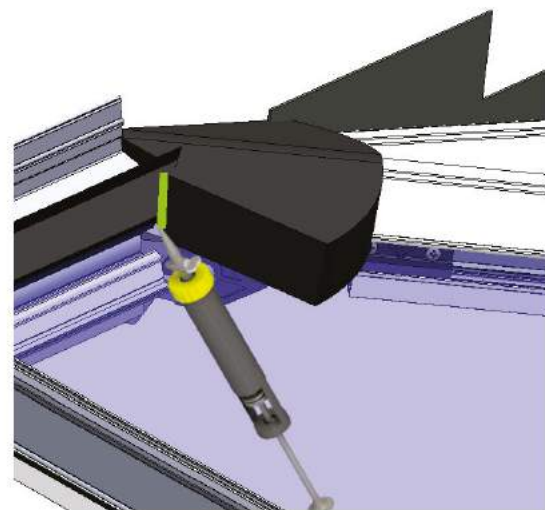
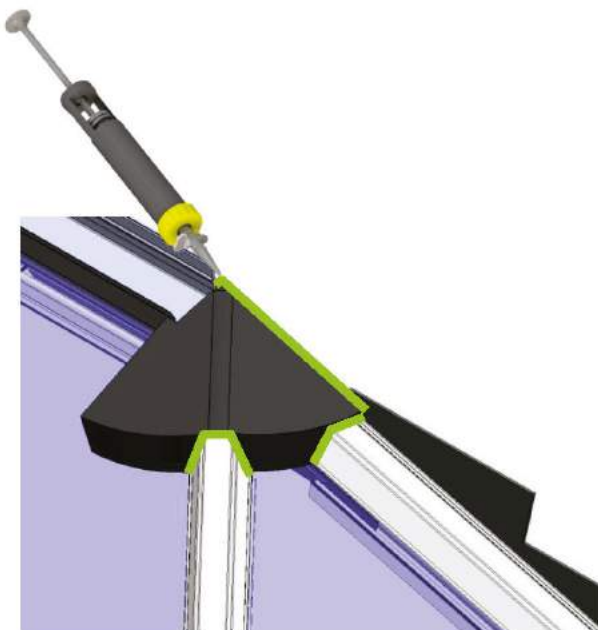

5.08 – Hipped Lean To – Wallplate / Half Ridge Cover Assembly & Flashing

This section shows how to fit the wallplate / half ridge cover assembly. The ridge cover and square/round external cover will come pre-assembled with roof kits. The end plate and flashing trim will then be attached to this.



Related Components ...



Wallplate Cover Assembly



Half Ridge
Cover Assembly



LZPE0050



LZMP0017



LZMP0014



LZPE0047

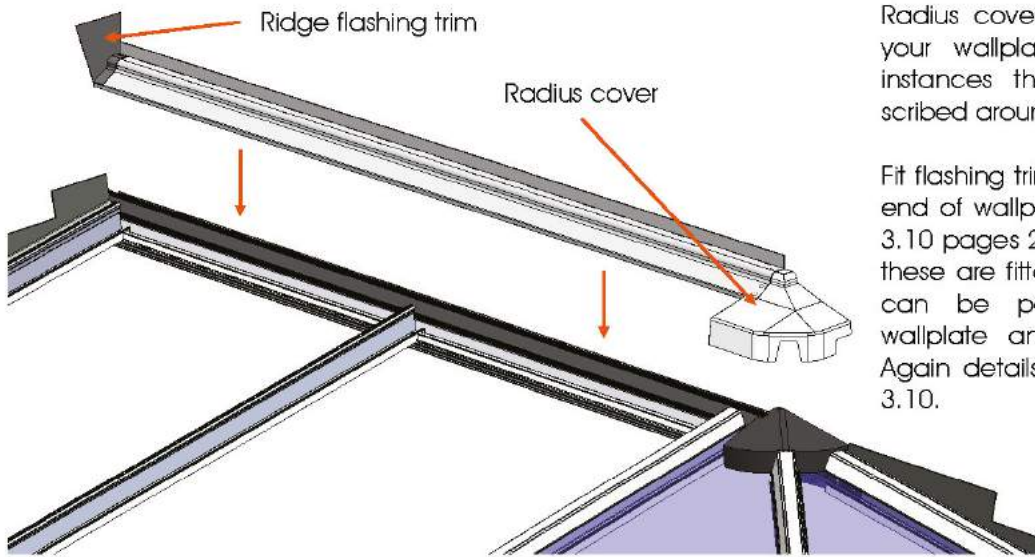

Radius covers are factory fitted to your wallplate cover. In some instances these will need to be scribed around hip bars.

Fit flashing trims or end plates to the end of wallplate cover, see section 3.10 pages 24-25 for details. Once these are fitted, the wallplate cover can be positioned on to the wallplate and secured in place. Again details are shown in section 3.10.

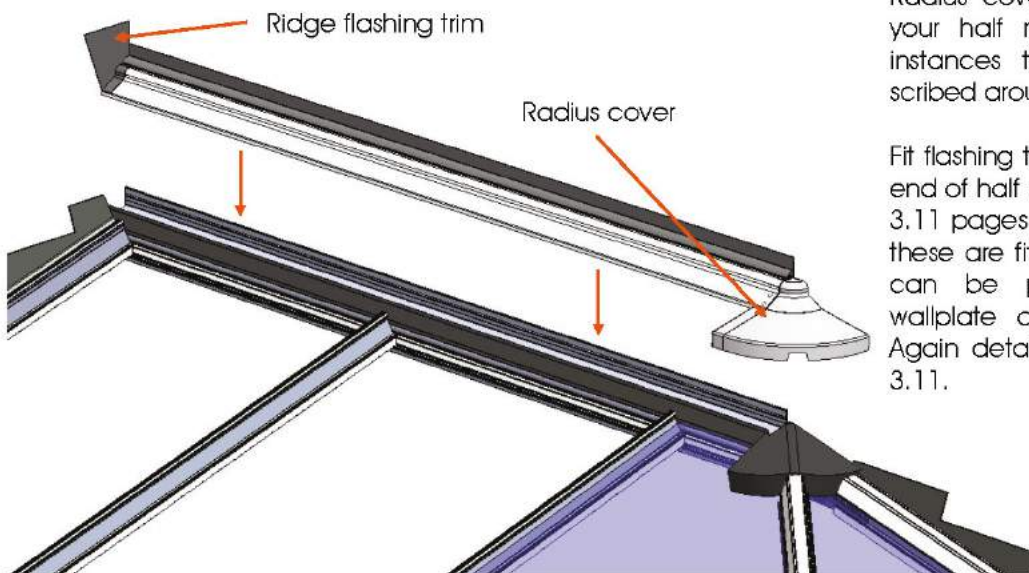

Radius covers are factory fitted to your half ridge cover. In some instances these will need to be scribed around hip bars.

Fit flashing trims or end plates to the end of half ridge covers, see section 3.11 pages 26-27 for details. Once these are fitted, the wallplate cover can be positioned on to the wallplate and secured in place. Again details are shown in section 3.11.

The final pieces of flashing can now be fitted over the ridge flashing trim (where fitted), the radius cover and the wallplate / half ridge. See section 3.12 pages 28-29 for details.

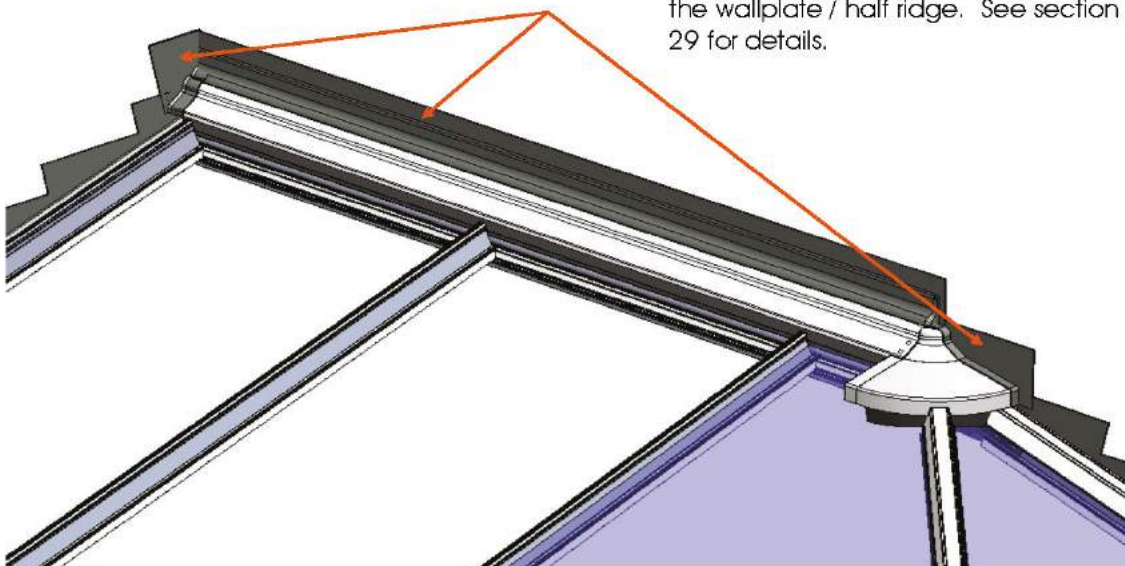

5.09 – Hipped Lean To – Internal Cover Assembly

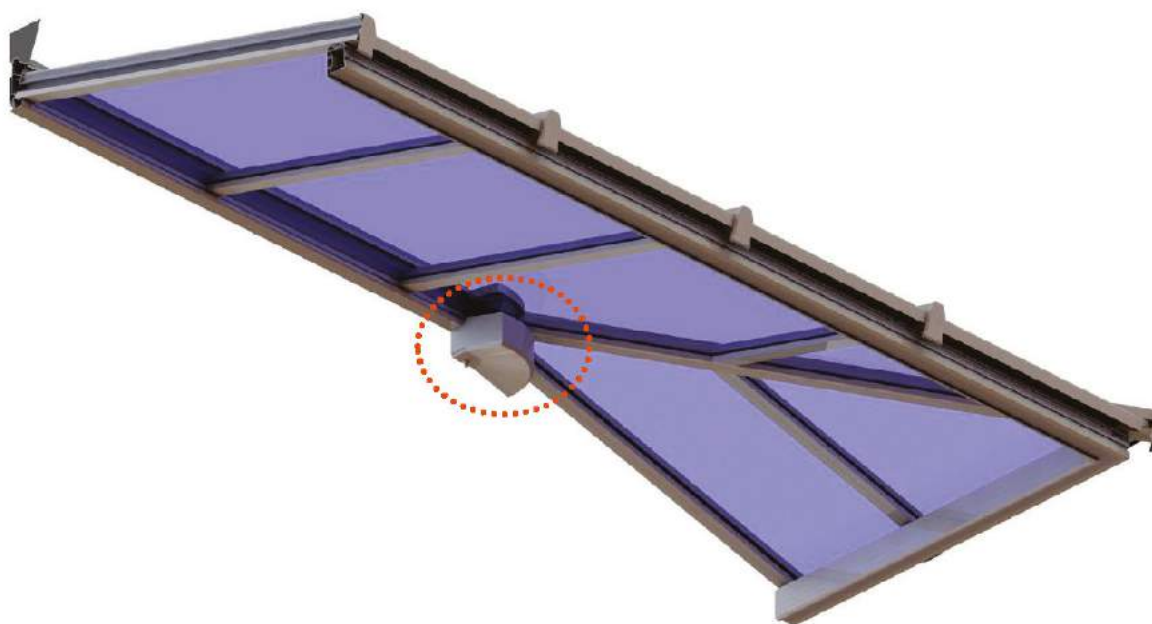
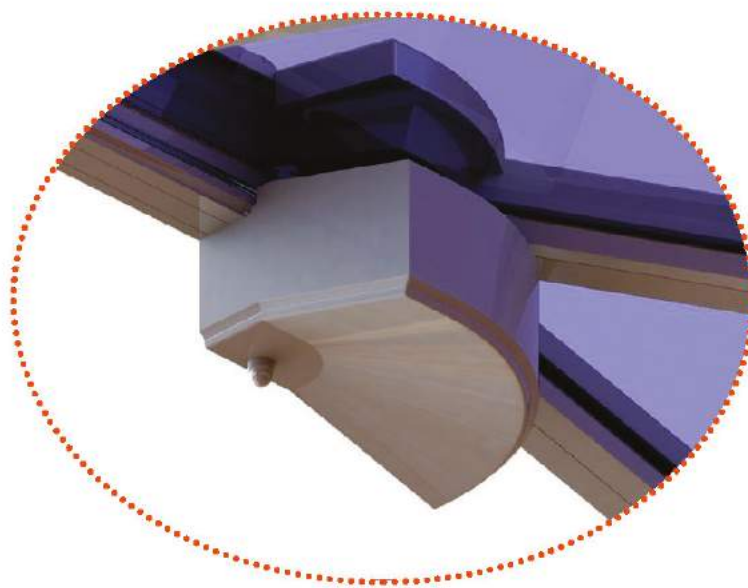

Related Components ...



Internal Covers



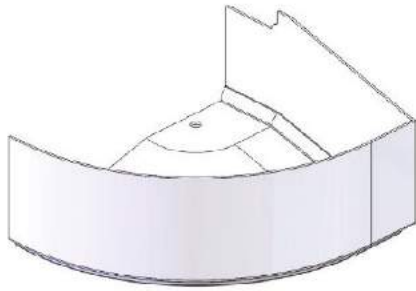

LZMP0049

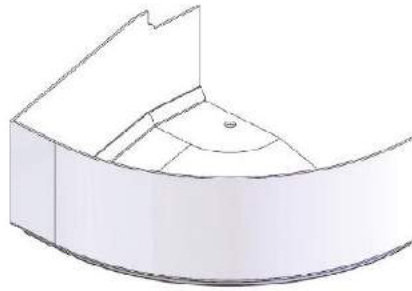

LZMP0050

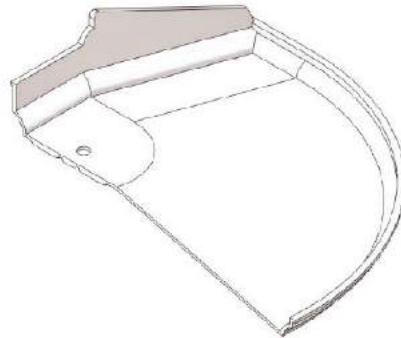

LZMP0037

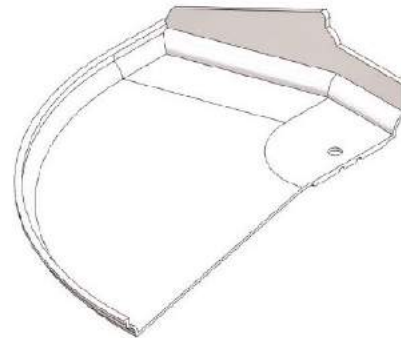

LZMP0038

1. Insert the 130mm stud (LZSU0055) into the half D-ring.
2. You will need to prep the internal cover by drilling a 10mm pilot hole through the centre.
3. Then push the internal cover onto the studding and fit an M10 nut to secure in place.
4. Finally, cap the M10 nut with a nut cap.

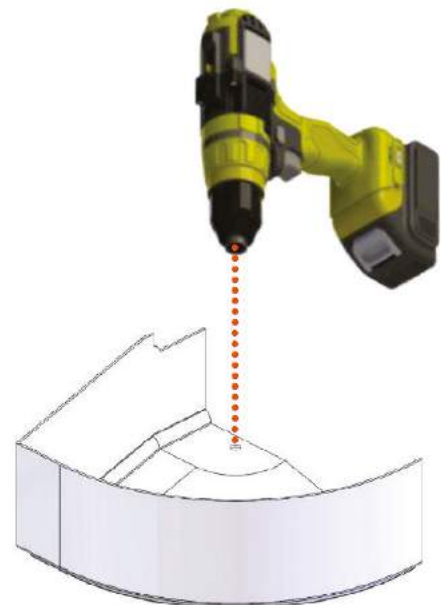
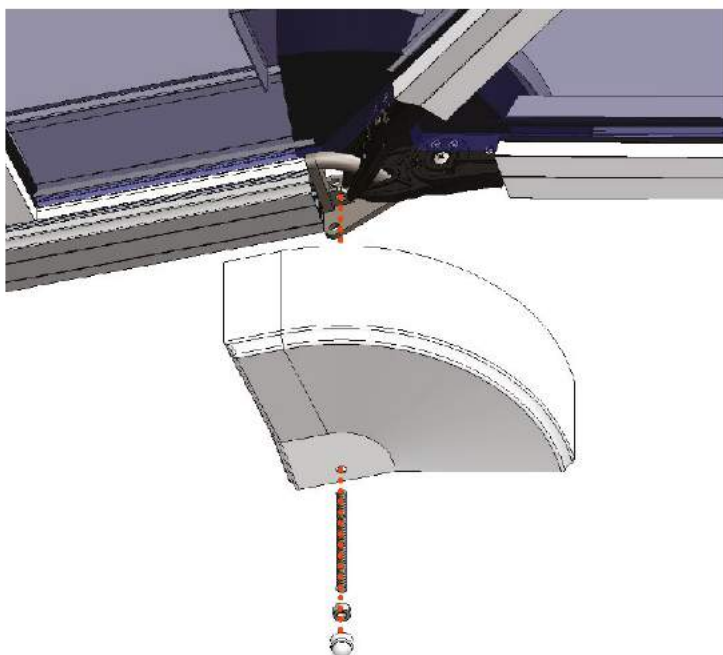

6.00 – Guttering Assembly

This section details the installation of the guttering.

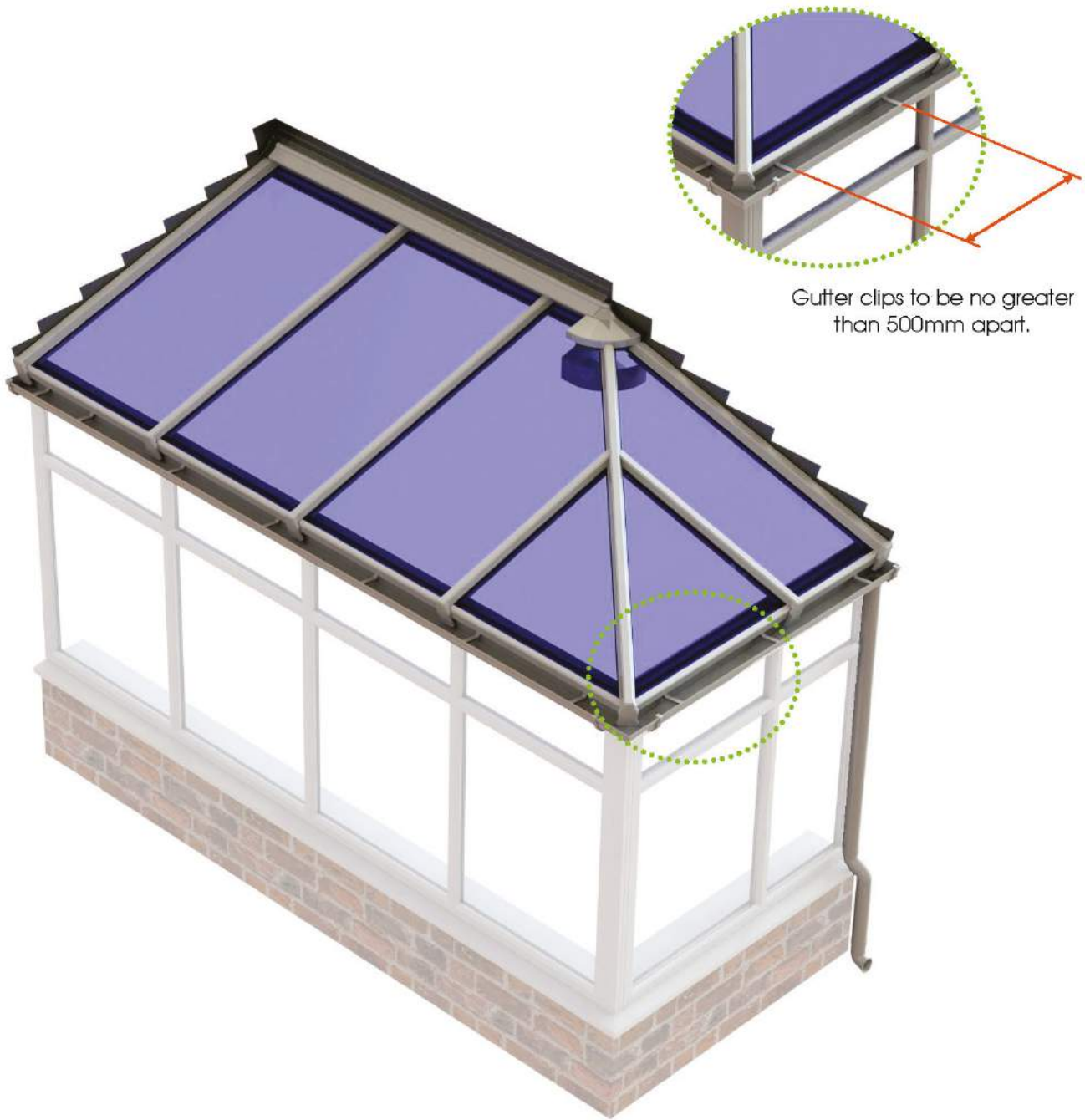

Related Components ...



LZR8710



LZR8700



LZR88320



LZR8701



LZR8702



LZR8720



LZR8730



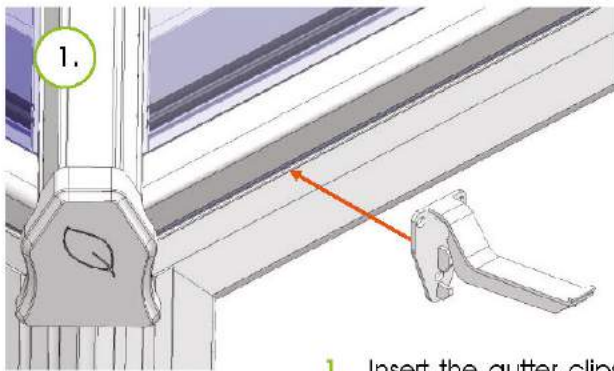

1. Insert the gutter clips into the eaves beam by clipping into place as shown above. Gutter clips should be spaced evenly along the eaves beam at no greater than 500mm intervals. They should also be positioned no greater than 150mm from corners.



2. Determine where the downpipe will be, drill a 60mm hole in the guttering and fit the multi-positional outlet.

3. Fit all stop ends to the guttering.

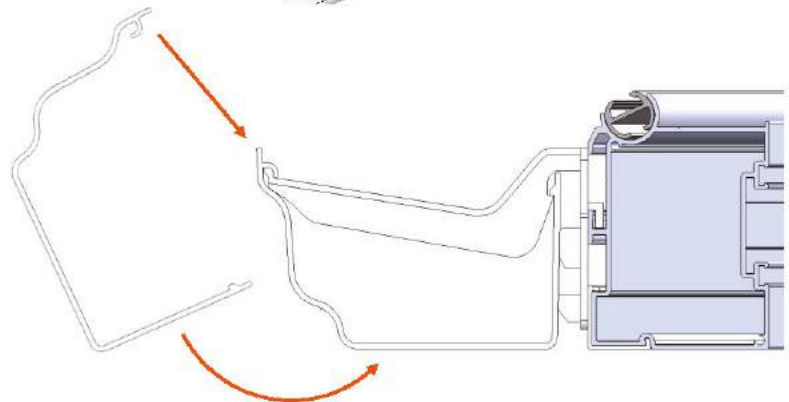
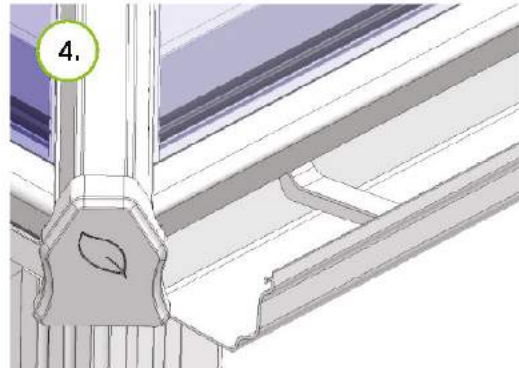
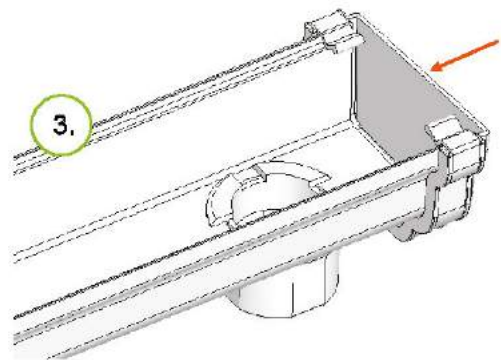

4. Install the guttering to the gutter clips by firstly hooking the outside edge on to the end of all the clips. Once attached to all clips, rotate the guttering towards the eaves until it locks into place.

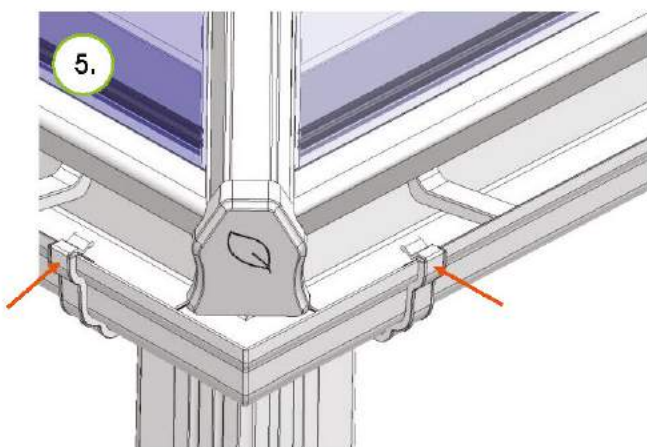

5. Now fit both the gutter angle joints, ensuring all seals are in correct position and all clips are in place.

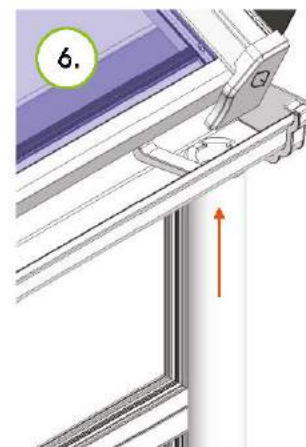

6. Connect the downpipe to the multi-positional outlet.

7.00 – Wall Pivot Rail

The wall pivot rail assembly eliminates the need for the use of rainwater goods. It is ideal for use in lantern roof applications. We suggest that the timber sub-frame is dressed with the roof membrane/finish before the roof is installed. Run two lines of appropriate sealant around the perimeter and apply a line of sealant to mitre cuts. Bed the wall pivot rail into the sealant. The wall pivot rail should then be secured with appropriate proprietary fixings at 600mm centres (150mm from corners).

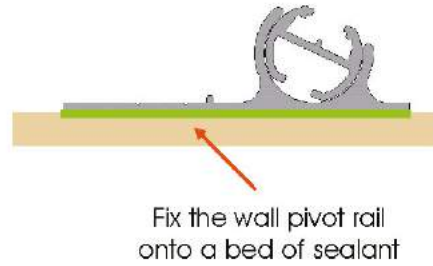
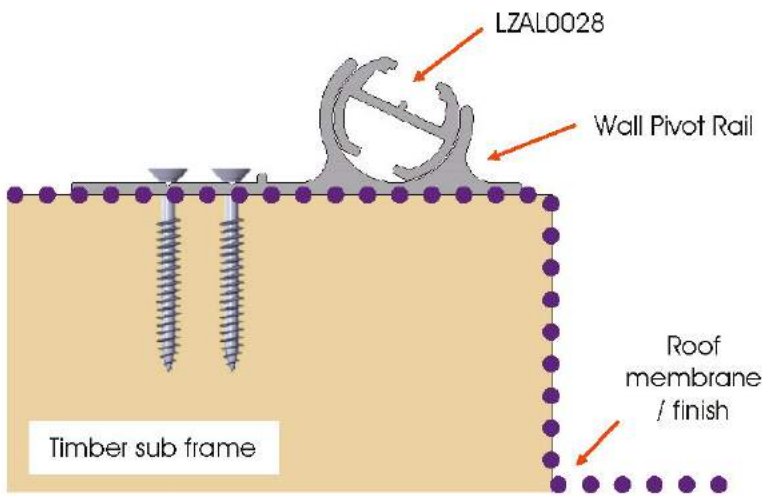

Ensure suitable clearance around the sub-frame for the roof bar end caps (LZMP0052). Linar provides a report detailing the height required whenever a wall pivot rail is used.

Related Components ...



LZAL0044



LZSU0001



LZSU0002



LZFX0004



8.00 – Muntin Bar and Roof Vent Assembly

This section details the installation of muntin bars and roof vents. For further details see the manufacturer's instructions supplied with your roof vent and muntin bar.

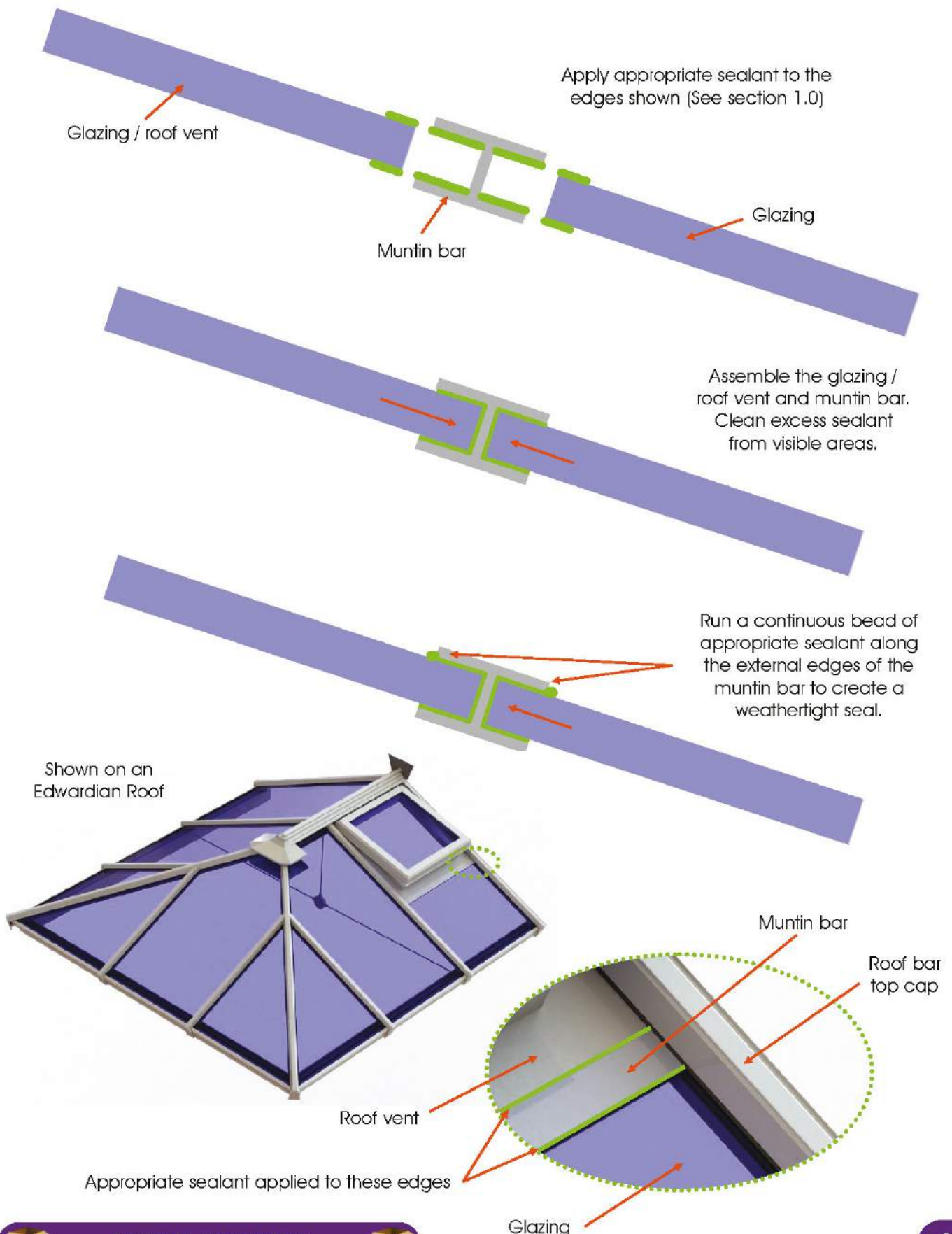

Installation supplies

Ensure a fully matching conservatory with Liniar's range of approved installation supplies. From the highest quality foam trims to coloured silicone sealants, you can be sure of a perfect match – all covered by the Liniar guarantee.

The range includes PVCu and glass cleaners, adhesives, window boards, fixings and accessories. For full details see www.liniar.co.uk/supplies.



Installer support

Liniar provides installers with a variety of marketing tools and resources, helping you to grow your own business alongside ours.

PDF copies of brochures, fact sheets and other literature are available to download from the Liniar website at www.liniar.co.uk/downloads and you can also order full boxes by contacting the Liniar sales office.



After-sales support is available in the form of a Liniar roof maintenance guide.

A video library is also to hand on the Liniar website, featuring a range of sales and installation videos for you to use and show to customers.

Follow Liniar on social media for the latest news and updates:

Twitter	@LiniarProfiles
LinkedIn	Liniar
Facebook	LiniarUK
Pinterest	LiniarUK
Google+	LiniarUK
YouTube	LiniarUK



Liniar

Flamstead House
Denby Hall Business Park
Denby
Derbyshire DE5 8JX

Tel: +44 (0)1332 883900
Fax: +44 (0)1332 883901
Email: sales@liniar.co.uk

www.liniar.co.uk

